

PB-Series

GFCI / ELCI & Panel Seal

PRODUCT WEBPAGE

request sample, configure part

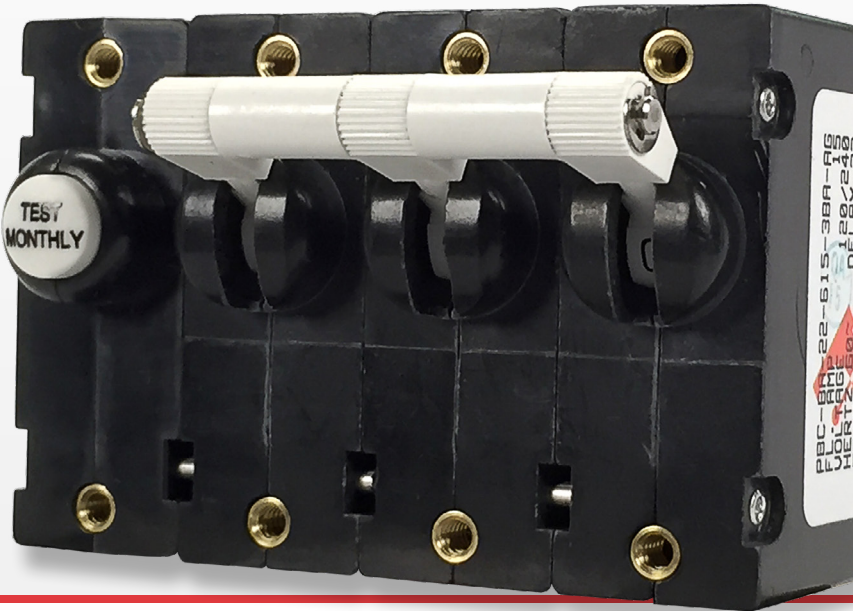

The PB-Series, AC Residual Current Circuit Breaker with Overcurrent Protection (RCBO), combines the ground fault protection of a GFCI with the familiar overcurrent tripping characteristics of a normal circuit breaker. It utilizes the hydraulic magnetic principle which provides precise operation and performance even when exposed to extremely hot and/or cold application environments.

1-3 Poles **0.1-30 Amps** **120/240 VAC** **5,000A Max**
Interrupting Capacity

Typical Applications

- Marine
- Generators
- Lighting

Tech Specs

Electrical

Maximum Voltage	120/240VAC 60 Hz
Current Ratings	Standard current coils: 0.100, 0.250, 0.500, 0.750, 1.00, 2.50, 5.00, 7.50, 10.0, 15.0, 20.0, 25.0 & 30.0 amps. Other ratings available, see ordering scheme.
Insulation Resistance	Minimum of 100 Megohms at 500 VDC
Dielectric Strength	UL, CUL - 1500 V 60 Hz for one minute between all electrically isolated terminals. PB-Series circuit breakers comply with the 8mm spacing and 3750V 60 Hz dielectric requirements from hazardous voltage to operator accessible surfaces and between adjacent poles
Impedance	Values from Line to Load Terminal

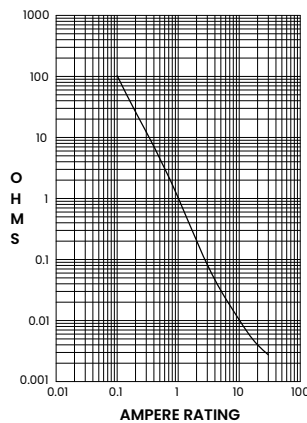

Ampere Rating	
CURRENT (AMPS)	TOLERANCE (%)
0.10 - 5.0	± 15
5.10 - 20.0	± 25
20.10 - 30.0	± 35

Pulse Tolerance Curve

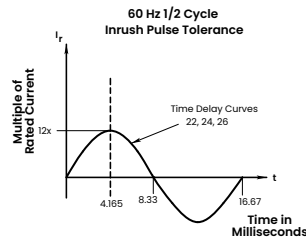

Leakage To Ground

Standard Must Trip	120/240VAC 60 Hz
Leakage Current Ratings	5 & 30 milliamps. 5± 1mA For other ratings, consult factory.
Trip Time	Minimum of 100 Megohms at 500 VDC.
Test Button	300 ms Max. @ 100%, 40ms Max. @ 500% of must trip leakage current.
Impedance	On unit face along side of actuator.

Tables

Table A: UL Listed configurations and performance capabilities as Circuit Breakers.

Electrical Ratings					
Circuit Configuration	Voltage			Current Rating (Amps)	Interrupting Capacity (Amps)
	Max Rating	Frequency	Phase		
Series	120	60	1	.10 - 30	5000
Series Ignition Protection					3000

Mechanical

Endurance	10,000 ON-OFF operations @ 6 per minute; with rated Current & Voltage.
Trip Free	All PB-Series Circuit Breakers will trip on overload or ground fault, even when Handle is forcibly held in the ON position.
Trip Indication	The operating Handle moves positively to the OFF position when an overload or ground fault causes the breaker to trip.

Physical

Number of Poles	1 - 3 poles, where the third pole is neutral
Internal Circuit Config.	Series Trip
Weight	Approximately 65 grams/pole. (2.32 ounces/pole.)
Standard Colors	Housing- Black; Actuator - See Ordering Scheme.

Environmental

Designed and tested in accordance with requirements of specification MIL-PRF- 55629 and MIL-STD-202 as follows:

Shock	Withstands 100 Gs, 6ms, sawtooth while carrying rated current per Method 213, Test Condition "I". Ultra-short curves tested @ 90% of rated current.
Vibration	Withstands 0.060" excursion from 10-55 Hz, and 10 Gs 55-500 Hz, at rated current per Method 204C, Test Condition A. Instantaneous and ultrashort curves tested at 90% of rated current.
Moisture Resistance	Method 106D, i.e., ten 24-hour cycles @ + 25°C to +65°C, 80-98% RH.
Salt Spray	Method 101, Condition A (90-95% RH @ 5% NaCl Solution, 96 hrs).
Thermal Shock	Method 107D, Condition A (Five cycles @ -55°C to +25°C to +85°C to +25°C).
Operating Temperature	-35° C to +65° C
Corrosion	Tested FMG Test. 3 weeks @ 30°C 75% RH, 100ppb H2S, 20ppb Cl2, 200ppb NO2

Agency Approvals

UL 489	Circuit Breakers, Molded Case, (Guide DIVQ, File E129899)
UL 1077	Supplementary Protectors
UL 1053	Ground Fault Sensing and Relaying Equipment

Ordering Scheme

Sample Part Number **PB B - B A - 24-620 - 2 B A - A G**

Selection 1 2 3 4 5 6 7 8 9 10 11

1. SERIES

PB

2. SYSTEM VOLTAGE / POLES

- A 120 VAC single phase, one pole
- B 120/240 VAC single phase, two pole
- C 120/240 VAC single phase with switched neutral, three pole
- D 120 VAC two pole with switched neutral

3. POLES

B Series Trip (Current)

4. CIRCUIT

- | | |
|-------------------------------------|-----------------------------------|
| Handle | Single Color Curved Rocker |
| A one per pole | J Vertical legend |
| B one per multipole unit | K Horizontal legend |
| Two Color Curved Visi-Rocker | Two Color Flat Visi-Rocker |
| C Indicate ON, vertical legend | 1 Indicate OFF, vertical legend |
| D Indicate ON, horizontal legend | 2 Indicate OFF, horizontal legend |
| F Indicate OFF, vertical legend | Single Color Flat Rocker |
| G Indicate OFF, horizontal legend | 3 Vertical legend |
| | 4 Horizontal legend |

ROCKER STYLE DESCRIPTIONS					
	INDICATE "ON"	INDICATE "OFF"	SINGLE COLOR	INDICATE "OFF"	SINGLE COLOR
VERTICAL	CODE "C" 	CODE "F", "N" 	CODE "J", "R" 	CODE "1", "5" 	CODE "3", "7"
	CODE "D" 	CODE "G", "O" 	CODE "K", "U" 	CODE "2", "6" 	CODE "4", "8"
HORIZONTAL					

5. FREQUENCY & DELAY

- 21 50 / 60Hz Ultra Short
- 22 50 / 60Hz Short
- 24 50 / 60Hz Medium
- 26 50 / 60Hz Long

6. CURRENT RATING (AMPERES)

CODE	AMPERES	CODE	AMPERES	CODE	AMPERES	CODE	AMPERES
210	0.10	285	0.85	450	5.00	712	12.50
215	0.15	290	0.90	455	5.50	613	13.00
220	0.20	295	0.95	460	6.00	614	14.00
225	0.25	410	1.00	465	6.50	615	15.00
230	0.30	512	1.25	470	7.00	616	16.00
235	0.35	415	1.50	475	7.50	617	17.00
240	0.40	517	1.75	480	8.00	618	18.00
245	0.45	420	2.00	485	8.50	620	20.00
250	0.50	522	2.25	490	9.00	622	22.00
255	0.55	425	2.50	495	9.50	624	24.00
260	0.60	527	2.75	610	10.00	625	25.00
265	0.65	430	3.00	710	10.50	630	30.00
270	0.70	435	3.50	611	11.00		
275	0.75	440	4.00	711	11.50		
280	0.80	445	4.50	612	12.00		

7. TERMINAL 2

- 1³ Push-On 0.250 Tab (Q.C.)
- 2 Screw 8-32 w/upturned lugs
- 3 Screw 8-32 (Bus Type)
- 4 Screw 10-32 w/upturned lugs
- 5 Screw 10-32 (Bus Type)
- B Screw M5 w/upturned lugs
- C Screw M4 w/upturned lugs
- E Screw M4 (Bus Type)
- H Screw M5 (Bus Type)

8. ACTUATOR COLOR & LEGEND

Handle Color	I-O	ON-OFF	Dual	Single	Visi-Rocker
White	A	B	1	Black	White
Black	C	D	2	White	N/A
Red	F	G	3	White	Red
Green	H	J	4	White	Green
Blue	K	L	5	White	Blue
Yellow	M	N	6	Black	Yellow
Gray	P	Q	7	Black	Gray
Orange	R	S	8	Black	Orange

9. MOUNTING / BARRIERS

- | | | |
|---|--|----------|
| | MOUNTING STYLE | |
| | Threaded Insert, 2 per pole | BARRIERS |
| A | 6-32 X 0.195 inches | yes |
| B | M3 x 5mm | yes |
| | Rockerguard Bezel, 2 per pole | |
| C | 6-32 x 0.195" | yes |
| D | M3 x 5 mm | yes |
| | Standard Bezel with Recessed Off-Side Flat Rocker | |
| | Threaded Insert, 2 per pole | |
| E | 6-32 x 0.195" | yes |
| F | M3 x 5 mm | yes |

10. LEAKAGE CURRENT TRIP LEVEL - MAX. TRIP CURRENT

- A³ 5 MA (CLASS A GFCI)
- E 30 MA (ELCI)

11. AGENCY APPROVAL

- A without Approvals
- G UL489 Listed, CSA Certified
- C UL1077
- I⁴ UL1077 / UL1500 Ignition Protected

Notes:

- 1 Actuator Code:
 - A: Handle tie pin spacer(s) and retainers provided unassembled with multi-pole units.
 - B: Handle location as viewed from front of breaker:
 - 2 pole - left pole 3 pole - center pole
- 2 Screw Terminals are recommended on ratings greater than 20 amps.
- 3 30mA per UL1053, available with agency approval codes C & G.
- 4 UL1500 only available with 30MA trip level.

[Configure Complete Part Number >](#)

[Browse Standard Parts >](#)

Dimensional Specs

inches [millimeters]

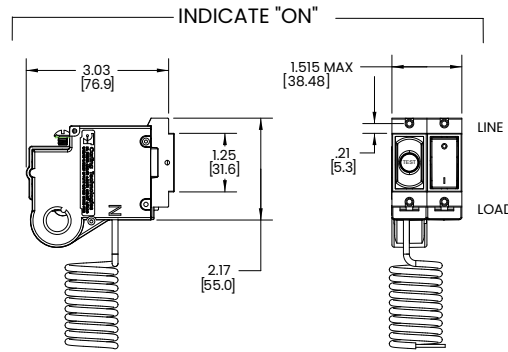

1-POLE 120 VAC VERSION

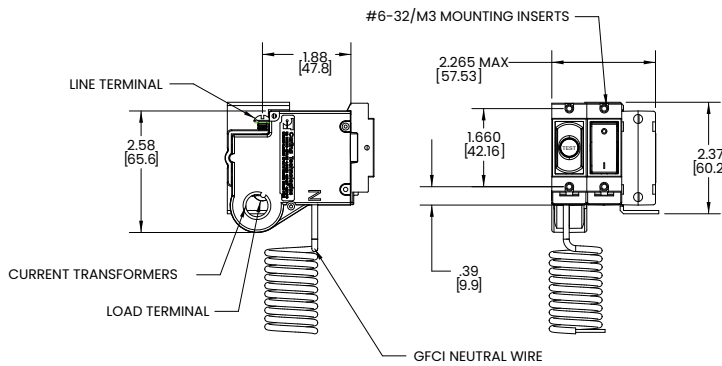
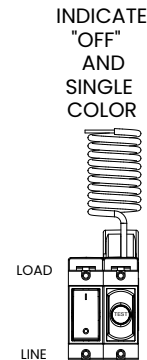

2-POLE 120/240 VAC VERSION

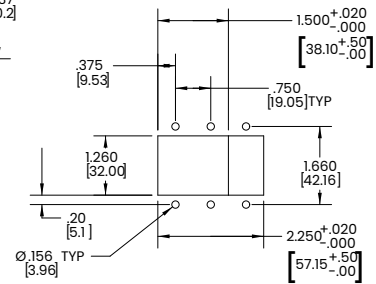

PANEL CUTOUT

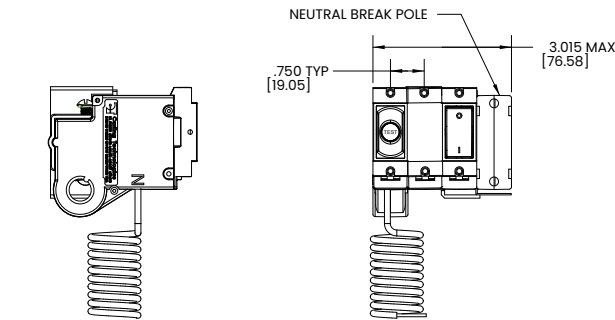

2-POLE 120/240 VAC WITH NEUTRAL BREAK

TERMINAL DIMENSIONAL DETAIL & RATING

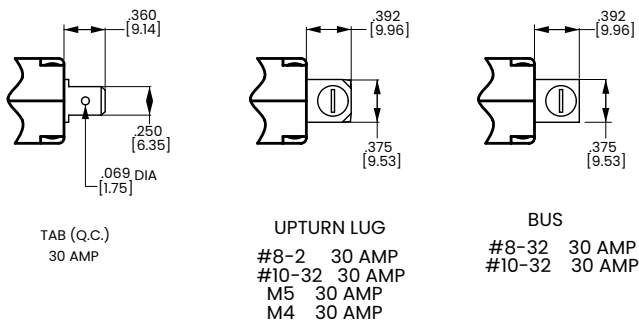

TABLE A
TIGHTENING TORQUE
SPECIFICATIONS

THREAD SIZE	TORQUE
#6-32 & M3 MOUNTING HARDWARE	7-9 IN-LBS [0.8-1.0 NM]
#8-32 & M4 THREAD TERMINAL SCREW	12-15 IN-LBS [1.4-1.7 NM]
#10-32 & M5 THREAD TERMINAL SCREW	15-20 IN-LBS [1.7-2.3 NM]

Notes:
1 Tolerance ± 0.020 [.51] unless otherwise specified.

Dimensional Specs

inches [millimeters]

TYPICAL 2-POLE 120 VAC VERSION

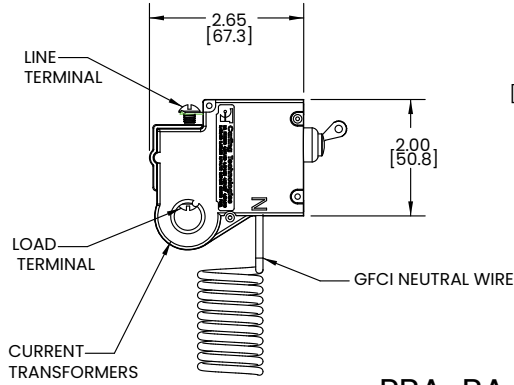

PBA-BA

TYPICAL 2-POLE 120/240 VAC WITH NEUTRAL BREAK VERSION

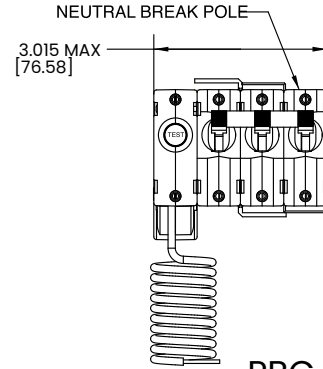
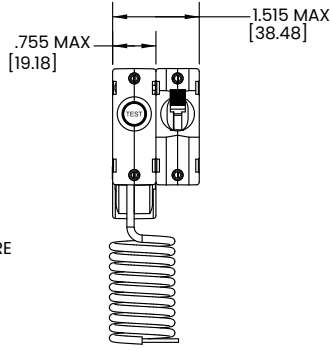

PBC-BA

TYPICAL 2-POLE 120/240 VAC VERSION

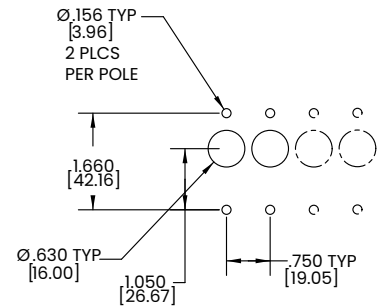
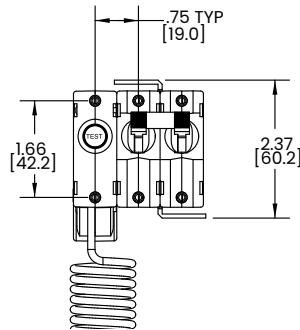
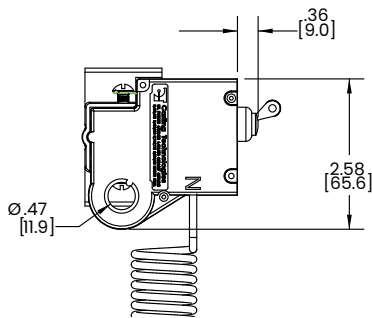

Notes:

1 Tolerance $\pm .020$ [.51] unless otherwise specified.

Wiring Diagrams

120 VAC with Switched Neutral

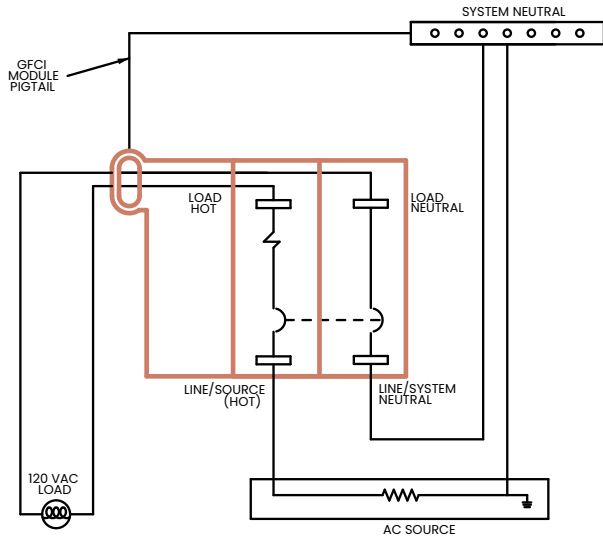

120 VAC WITH SWITCHED NEUTRAL

120 VAC without Switched Neutral

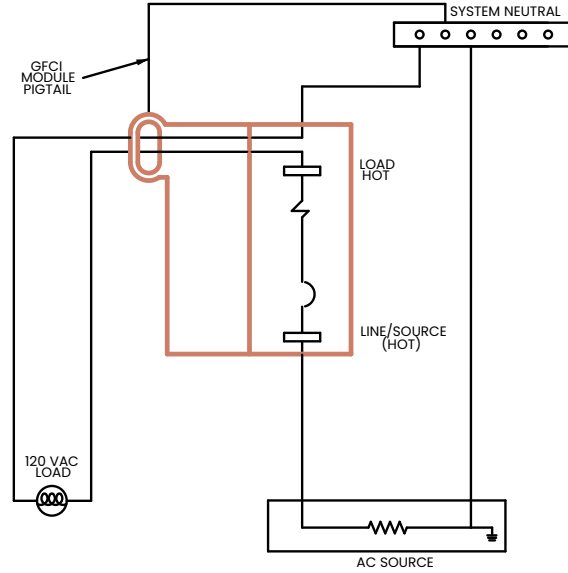

120 VAC WITHOUT SWITCHED NEUTRAL

120/240 VAC with Switched Neutral

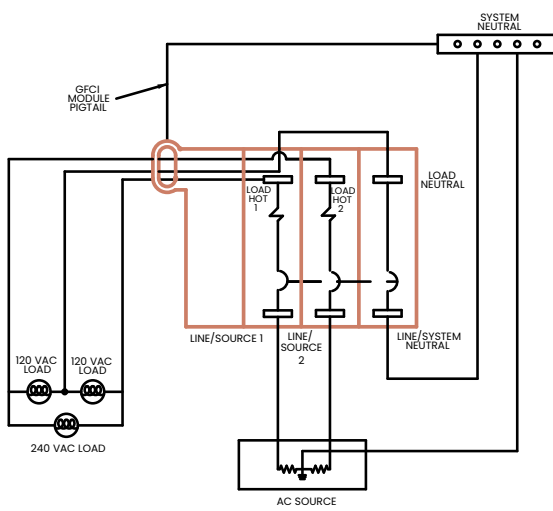

120 VAC WITH SWITCHED NEUTRAL

120/240 VAC without Switched Neutral

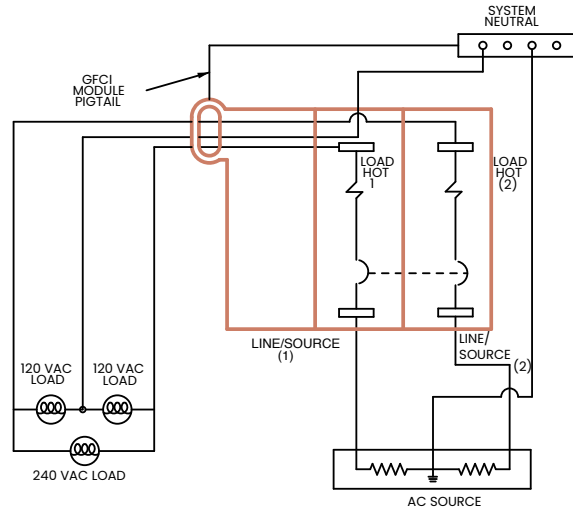

120 VAC WITHOUT SWITCHED NEUTRAL

Ordering Scheme

Sample Part Number 8 PB - 1 4 1

Selection 1 2 3 4 5

1. TYPE NUMBER

8

2. SERIES

PB

3. ACTUATOR TYPE

- 1 Handle, one per pole
- 2 Handle, one per multipole unit
- A Rocker ²

4. POLES PER UNIT - INCLUDING ELECTRONIC MODULE

- 2 Two
- 3 Three
- 4 Four

5. MOUNTING SCREWS / PLATE MATERIAL 1

- 1 6-32 Thread Phillips Head
- 2 M-3 Thread Phillips Head
- 3 6-32 Thread Slotted Head
- 4 M-3 Thread Slotted Head
- 5 6-32 Thread Phillips Head with Stainless Steel Plate
- 6 M-3 Thread Phillips Head with Stainless Steel Plate
- 7 6-32 Thread Slotted Head with Stainless Steel Plate
- 8 M-3 Thread Slotted Head with Stainless Steel Plate

Notes:

- 1 Screws supplied to accommodate mounting panel thickness of $1/8" \pm 1/32"$. Consult Factory for additional options
- 2 Available for Flat and Curved Rocker options - No Rockerguard Bracket

Handle Style Panel Seal

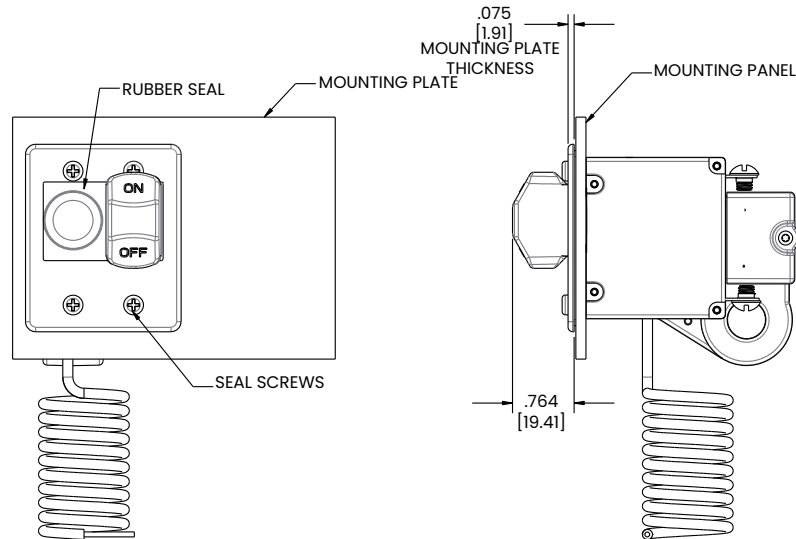

Rocker Style Panel Seal

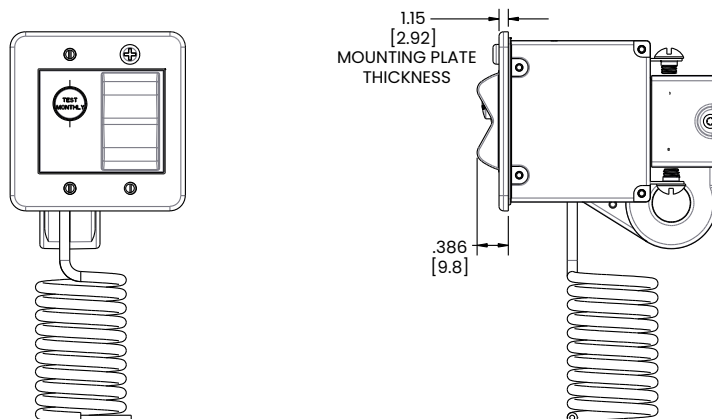

Dimensional Specs

Handle Actuator

HANDLE, 1 PER POLE

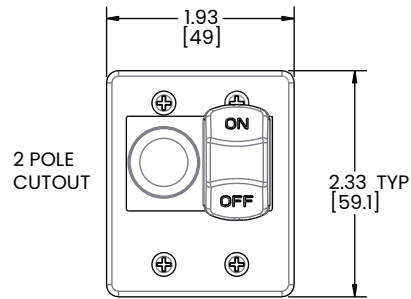

8PB-12

HANDLE, 1 PER MULTIPOLE UNIT

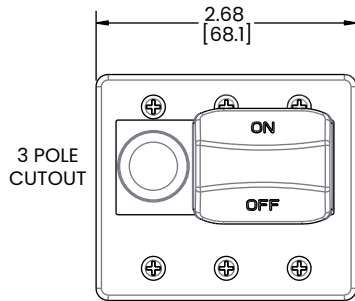

8PB-13

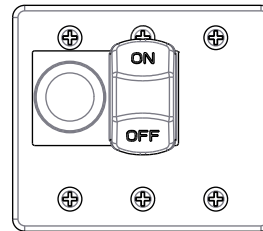

8PB-23

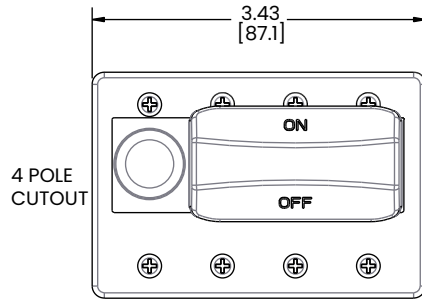

8PB-14

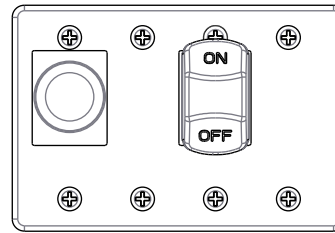

8PB-24

Rocker Actuator

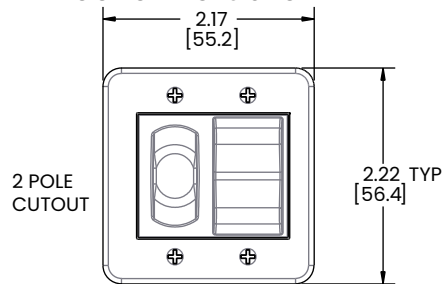

8PB-A2

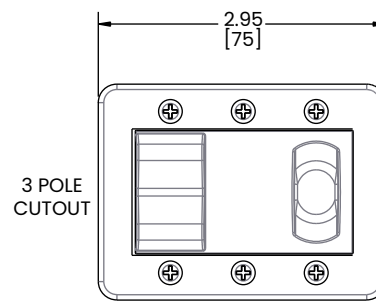

8PB-A3

Time Delay

Ultra Short

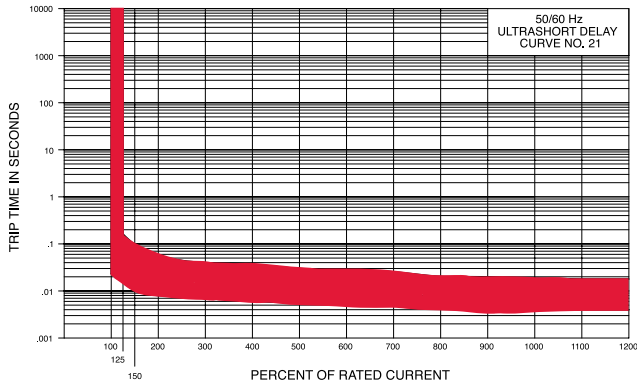

Medium

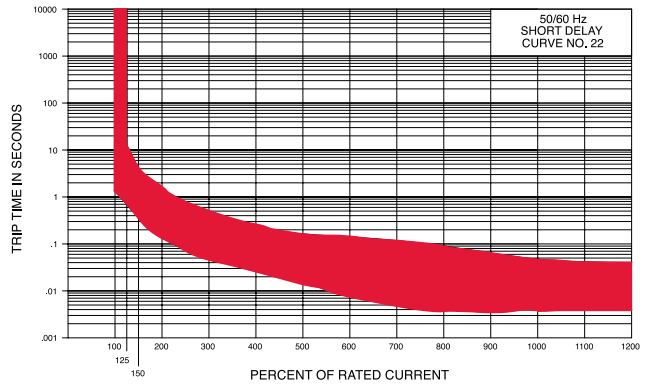

Short

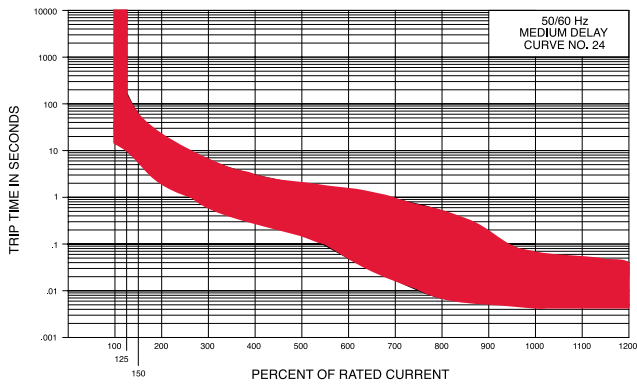

Long

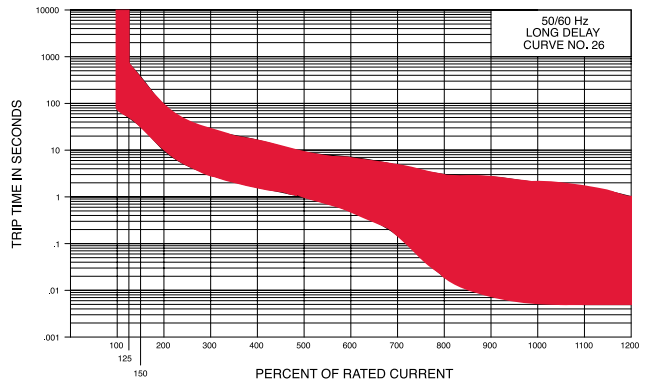

Authorized Sales Representatives and Distributors

Click on a region of the map below to find your local representatives and distributors or visit www.carlingtech.com/findarep.



About Carling

Founded in 1920, Carling Technologies is a leading manufacturer of electrical and electronic switches and assemblies, circuit breakers, electronic controls, power distribution units, and multiplexed power distribution systems. With six ISO9001 and IATF16949 registered manufacturing facilities and technical sales offices worldwide, Carling Technologies Sales, Service and Engineering teams do much more than manufacture electrical components, they engineer powerful solutions! To learn more about Carling please visit www.carlingtech.com/company-profile.

To view all of Carling's environmental, quality, health & safety certifications please visit www.carlingtech.com/environmental-certifications.

© Carling Technologies, Inc.

10. Carling is a registered trademark of Carling Technologies, Inc. in the U.S. and other countries.