

A-Series

Hydraulic-Magnetic Circuit Breaker

PRODUCT WEBPAGE

request sample, configure part



Compact and Versatile Design

The A-Series hydraulic-magnetic circuit breakers offer precise operation in a compact size for both general purpose as well as full amp load applications. Visi Rocker® and recessed paddle actuators are ideally suited for clean, front panel designs while the metal toggle configuration is ideal for harsh environments. The A-Series is available as a one to six pole configuration, rated up to 50 amps, 277VAC/80VDC and has a max IC of 5,000 amps.

1-6	50	277	80	5000A
Poles	Amps Max	VAC Max	VDC Max	Max IC

Typical Applications

- Datacom/Telecom
- Renewable Energy
- Welders
- Marine
- Generators
- Military

Tech Specs

Electrical

Maximum Voltage	277VAC 50/60 Hz, 80VDC
Current Ratings	Standard current coils: 0.100, 0.250, 0.500, 0.750, 1.00, 2.50, 5.00, 7.50, 10.0, 15.0, 20.0, 25.0, 30.0, 35.0, 40.0, 50.0. Other ratings available - consult ordering scheme.
Standard Voltage Coils	DC-6V, 12V; AC-120V, Other ratings available, consult ordering scheme.
Auxiliary Switch Rating	SPDT; 10.1 A - 250VAC, 1.0 A-65VDC/0.5 A - 80 VDC, 0.1A - 125VAC (with gold contacts)
Insulation Resistance	Minimum: 100 Megohms at 500 VDC
Dielectric Strength	UL, CSA - 1500V 60 Hz for one minute between all electrically isolated terminals. A-Series rocker circuit breakers comply with the 8mm spacing & 3750V dielectric requirements from hazardous voltage to operator accessible surfaces per EN 60950 and VDE 0805.
Resistance, Impedance	Values from Line to Load Terminal based on Series Trip Circuit Breaker.

RESISTANCE PER POLE VALUES
from Line to Load Terminals
(Values Based on Series Trip Circuit Breaker)

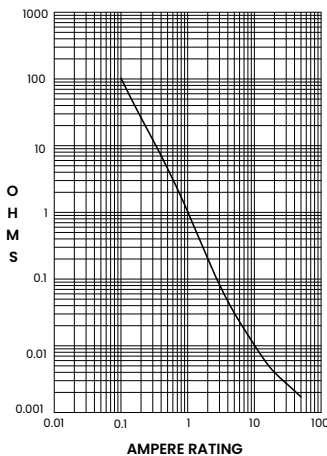

CURRENT (AMPS)	TOLERANCE (%)
0.10 - 5.0	15
5.1 - 20.0	25
20.1 - 50.0	35

Pulse Tolerance Curves

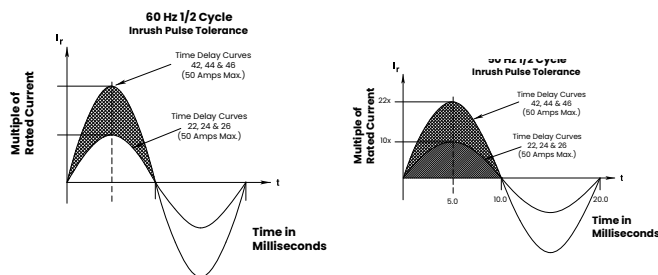

Mechanical

Endurance	10,000 ON-OFF operations @ 6 per minute; with rated Current & Voltage.
Trip Free	All A-Series Circuit Breakers will trip on overload, even when the actuator is forcibly held in the ON position.
Trip Indication	The operating actuator moves positively to the OFF position when an overload causes the circuit breaker to trip. When mid-trip handle is specified, the handle moves to the mid position on electrical trip of the circuit breaker. When mid-trip handle with alarm switch is specified, the handle moves to the mid position & the alarm switch actuates when the circuit breaker is electrically tripped

Physical

Number of Poles	1 - 6 Poles (handle) and 1-3 poles (rocker) at 30 Amps or less.1 and 2 poles at 31 Amps thru 50 Amps.
Internal Circuit Config.	Series, (with or without auxiliary switch), Shunt and Relay with current or voltage trip coils, Dual Coil, Switch Only with or without auxiliary switch.
Weight	Approximately 65 grams/pole. (Approximately 2.32 ounces/pole)
Standard Colors	Housing - Black; Actuator- See Ordering Scheme.

Environmental

Designed and tested in accordance with requirements of specification MIL-PRF-55629 & MIL-STD-202 as follows:

Shock	Withstands 100 Gs, 6ms, sawtooth while carrying rated current per Method 213, Test Condition "I". Instantaneous and ultra-short curves tested @ 90% of rated current.
Vibration	Withstands 0.060" excursion from 10-55 Hz, and 10 Gs 55-500 Hz, at rated current per Method 204C, Test Condition A. Instantaneous and ultrashort curves tested at 90% of rated current.
Moisture Resistance	Method 106D; ten 24-hour cycles @ +25°C to +65°C, 80-98% RH.56 days @ +85°C, 85% RH.
Salt Spray	Method 101, Condition A (90-95% RH @ 5% NaCl Solution, 96 hrs).
Thermal Shock	Method 107D, Condition A (Five cycles @ -55°C to +25°C to +85°C to +25°C).
Operating Temperature	-40° C to +85° C

Tech Specs

Electrical Tables

Table A: Lists UL Recognized & CSA Accepted configurations and performance capabilities as a Component Supplementary Protector.

Component Supplementary Protectors										
Circuit Configuration	Voltage			Current Rating		Short Circuit Capacity (Amps)		Application Codes		Notes
	Max Rating	Frequency	Phase	Full Load Amps	General Purpose Amps	UL / CSA		UL	CSA	
						With Backup Fuse	Without Backup Fuse			
Series	32	DC	---	0.02 - 15	---	---	5000	TC1, OLI, U2	TC1, OLI, U2	
	65	DC	---	31 - 50	---	---	7500	TC1, 2, OLI, U1	TC1, 2, OLI, U1	
	80	DC	---	0.02 - 30	---	---	7500	TC1, 2, OLI, U1	TC1, 2, OLI, U1	
				---	31 - 50	---	7500	TC1, 2, OL0, U1	TC1, 2, OL0, U1	
	125	50 / 60	1	0.02 - 30	---	---	3000	TC1, OLI, U2	TC1, OLI, U2	Rocker
	125	50 / 60	1	1 - 50	---	---	2000	TC1, OLI, U2	TC1, OLI, U2	
	125	50 / 60	1 ⁴	1 - 50	---	---	1000	TC1, OLI, U2	TC3, OLI, U3	
	125 / 250	50 / 60	1 ³	0.02 - 30	---	---	3000	TC1, 2, OLI, U2	TC1, 2, OLI, U2	Rocker
	125 / 250	50 / 60	1 ³	0.02 - 50	---	---	3000	TC1, 2, OLI, U2	TC1, 2, OLI, U2	Handle
	250	50 / 60	1	0.02 - 30	---	---	1500	TC1, 2, OL0, U2	TC1, 2, OL0, U2	Single Pole
				0.02 - 30	---	---	3000	TC1, OLI, U2	TC1, OLI, U2	Two Pole
				---	---	---	3000	TC1, 2, OL0, U1	TC1, 2, OL0, U1	
				1 - 50	---	---	1000	TC1, OLI, U2	TC3, OLI, U3	
				0.02 - 30	---	5000 ²	---	TC1, 2, OLI, C1	TC1, 2, OLI, C1	
31 - 50				---	2000 ¹	---	TC1, 2, OLI, C1	TC1, 2, OLI, C1		
277	50 / 60	1	0.02 - 30	---	5000 ¹	---	TC1, 2, OLI, C1	TC1, 2, OLI, C1		
Dual Coil	32	DC	---	0.02 - 50	---	---	5000	TC1, OLI, U2	TC1, OLI, U2	
	65	DC	---	0.02 - 50	---	---	7500	TC1, 2, OLI, U1	TC1, 2, OLI, U1	
	80	DC	---	0.02 - 30	---	---	7500	TC1, 2, OLI, U1	TC1, 2, OLI, U1	
				---	31 - 50	---	7500	TC1, 2, OL0, U1	TC1, 2, OL0, U1	
	125	50 / 60	1	0.02 - 30	---	---	3000	TC1, OLI, U2	TC1, OLI, U2	Rocker
				1 - 50	---	---	2000	TC1, OLI, U2	TC1, OLI, U2	
	125	50 / 60	1 ⁴	0.02 - 30	---	---	1000	TC1, OLI, U2	TC3, OLI, U3	
	125 / 250	50 / 60	1 ³	0.02 - 30	---	---	3000	TC1, 2, OLI, U1	TC1, 2, OLI, U1	Rocker
	125 / 250	50 / 60	1 ³	0.02 - 50	---	---	3000	TC1, 2, OLI, U2	TC1, 2, OLI, U2	
	250	50 / 60	1	0.02 - 30	---	---	1500	TC1, OL0, U2	TC1, OL0, U2	Single Pole
				0.02 - 30	---	---	3000	TC1, OLI, U2	TC1, OLI, U2	Two Pole
				---	31 - 50	---	3000	TC1, 2, OL0, U1	TC1, 2, OL0, U1	
				1 - 50	---	---	1000	TC1, OLI, U2	TC3, OLI, U3	
				0.02 - 30	---	5000 ²	---	TC1, 2, OLI, C1	TC1, 2, OLI, C1	
31 - 50				---	2000 ¹	---	TC1, 2, OLI, C1	TC1, 2, OLI, C1		
277	50 / 60	1	0.02 - 30	---	5000 ¹	---	TC1, 2, OLI, U1	TC1, 2, OLI, U1		
Shunt	80	DC	---	0.02 - 30	---	---	7500	TC1, 2, OLI, U1	TC1, 2, OLI, U1	
	125 / 250	50 / 60	1	0.02 - 30	---	---	3000	TC1, 2, OLI, U1	TC1, 2, OLI, U1	
	250	50 / 60	1	0.02 - 30	---	---	3000	TC1, 2, OLI, U1	TC1, 2, OLI, U1	
				0.02 - 30	---	5000 ²	---	TC1, 2, OLI, C1	TC1, 2, OLI, C1	
	277	50 / 60	1	0.02 - 30	---	5000 ¹	---	TC1, 2, OLI, C1	TC1, 2, OLI, C1	
Relay	80	DC	---	0.02 - 30	---	---	7500	TC1, 2, OLI, U1	TC1, 2, OLI, U1	
	125 / 250	50 / 60	1 ³	0.02 - 30	---	---	3000	TC1, 2, OLI, U1	TC1, 2, OLI, U1	
	250	50 / 60	1	0.02 - 30	---	---	3000	TC1, 2, OLI, U1	TC1, 2, OLI, U1	
				0.02 - 30	---	5000 ²	---	TC1, 2, OLI, C1	TC1, 2, OLI, C1	
	277	50 / 60	1	0.02 - 30	---	5000 ¹	---	TC1, 2, OLI, C1	TC1, 2, OLI, C1	
Switch Only	65	DC	---	0.02 - 50	---	not applicable				
	80	DC	---	0.02 - 30	---					
	250	50 / 60	1	---	31 - 50					
			3	0.02 - 50	---					
	277	50 / 60	1	0.02 - 30	31 - 50					

Notes:

- 1 Requires branch circuit backup with a UL LISTED Type K5 or RK5 fuse (15A minimum) at no more than 4 times the rating of the protector.
- 2 Same as note 1, except that backup fuse is limited to 80 A maximum.
- 3 2 pole protector required (with one pole per power line) for: 125/250 VAC, 1 pole protector required for: 125 VAC, 1Ø Power System.
- 4 Satisfies the requirements of clause 11.2.8.2.5 of CSA STD C22.2 No 100 for the use of supplementary protectors with portable generators.

Tech Specs

Electrical Tables

Table B: Lists UL Recognized, CSA Accepted, VDE & TUV Certified configurations & performance capabilities as a Component Supplementary Protector.

Component Supplementary Protectors																										
Circuit Configuration	Voltage			Current Rating		Short Circuit Capacity (Amps)						Application Codes		Notes												
	Max Rating	Frequency	Phase	Full Load Amps	General Purpose Amps	UL / CSA		VDE		TUV		UL	CSA													
						With Backup Fuse	Without Backup Fuse	(Inc) with Backup Fuse	(Inc) without Backup Fuse	(Inc) with Backup Fuse	(Inc) without Backup Fuse															
Series	65	DC	---	0.10 - 50	---	---	7500	---	---	5000	3000	TCI, 2, OLI, UI	TCI, 2, OLI, UI	World Market Breaker TUV only												
				0.10 - 30	---									TCI, 2, OLI, UI	TCI, 2, OLI, UI	Handle: 1 Pole										
	80	DC	---	0.10 - 30	---	---	7500	3000	1500	3000	1500	1500	TCI, 2, OLI, UI	TCI, 2, OLI, UI	TCI, 2, OLI, UI											
				31 - 50	31 - 50										TCI, 2, OLI, UI	TCI, 2, OLI, UI	Rocker: 1-3 Poles									
				0.10 - 30	---										TCI, 2, OLI, UI	TCI, 2, OLI, UI	Rocker: 2 Pole									
				31 - 32	---										TCI, 2, OLI, UI	TCI, 2, OLI, UI	Rocker: 1 Pole									
				31 - 50	31 - 50										TCI, 2, OLI, UI	TCI, 2, OLI, UI	Rocker: 1 Pole									
				0.10 - 30	---										TCI, 2, OLI, UI	TCI, 2, OLI, UI	Rocker: 1-3 Poles									
	250	50 / 60	1	0.10 - 30	---	---	3000	---	3000	1500	5000	1500	TCI, 2, OLI, UI	TCI, 2, OLI, UI	TCI, 2, OLI, UI											
				31 - 50	31 - 50										TCI, 2, OLI, UI	TCI, 2, OLI, UI	Rocker: 1-3 Poles									
				0.10 - 30	---										TCI, 2, OLI, UI	TCI, 2, OLI, UI	Rocker: 2 Pole									
				31 - 32	---										TCI, 2, OLI, UI	TCI, 2, OLI, UI	Rocker: 2 Pole									
				1	0.10 - 30										---	1000	---	---	---	---	---	---	---	---	---	---
				1 ⁴	1 - 50										---	---	---	---	---	---	---	---	---	---	---	---
3				0.10 - 30	---										5000 ³	---	3000	1500	3000	---	---	---	---	---	---	
3				31 - 50	---										2000 ²	---	---	---	---	---	---	---	---	---	---	
Dual Coil	80	DC	---	0.10 - 30	---	---	7500	3000	1500	3000	1500	TCI, 2, OLI, UI	TCI, 2, OLI, UI	Rocker: 1-3 Poles												
				0.10 - 30	---										3000	---	5000									
	250	50 / 60	1	0.10 - 30	---	---	5000 ³	---	3000	1500	3000	1500	TCI, 2, OLI, UI	TCI, 2, OLI, UI	Rocker: 1-3 Poles											
				30 - 50	31 - 50											---	---	---								
				0.10 - 30	---											---	---	---	---	---	---					
				31 - 50	---											---	---	---	---	---	---					
Shunt	80	DC	---	0.10 - 30	---	---	7500	3000	1500	3000	1500	TCI, 2, OLI, UI	TCI, 2, OLI, UI	Handle: 1 Pole												
				0.10 - 30	---										3000	---	5000									
	250	50 / 60	1	0.10 - 30	---	---	5000 ³	---	3000	1500	3000	1500	TCI, 2, OLI, UI	TCI, 2, OLI, UI	Rocker: 1-3 Poles											
				30 - 50	31 - 50											---	---	---								
				0.10 - 30	---											---	---	---	---	---	---					
				31 - 50	---											---	---	---	---	---	---					
				3	0.10 - 30											---	5000 ³	---	3000	1500	3000	---	---	---	---	---
				3	31 - 50											---	2000 ²	---	---	---	---	---	---	---	---	---

Notes:

- 1 General Purpose Ratings for UL/CSA Only.
- 2 Requires branch circuit backup with a UL LISTED Type K5 or RK5 fuse (15A minimum) at no more than 4 times the rating of the protector.
- 3 Same as note 2, except that backup fuse is limited to 80 A maximum.
- 4 Satisfies the requirements of clause 11.2.8.2.5 of CSA STD C22.2 No 100 for the use of supplementary protectors with portable generators.

Tech Specs

Electrical Tables

Table C: Lists UL Recognized, CSA Accepted configurations and performance capabilities as Protectors, Supplementary for Marine Electrical and Fuel Systems (Guide PEQZ2, File E75596). Ignition Protected per UL 1500. UL Classified Small Craft Electrical Devices, Marine in accordance with ISO 8846 (Guide UZMK, File MQ1515) as Marine Supplementary Protectors.

UL1500 (Marine Ignition Protection)							
Circuit Configuration	Voltage			Current Rating Full Load Amps	Short Circuit Capacity (Amps) Without Backup Fuse	Application Codes	
	Max Rating	Frequency	Phase			UL	CSA
Series	14 ¹	DC	---	0.02 - 50	5000	TC1, OLI, U1	TC1, OLI, U1
	32 ¹					TC1, OLI, U2	TC1, OLI, U2
	65					TC1, OLI, U1	TC1, OLI, U1
	125	50 / 60	1		3000	TC1, OLI, U2	TC1, OLI, U2
	125 / 250		1 ²			TC1, OLI, U2	TC1, OLI, U2
	250		1			0.02 - 30	1500

¹ Notes:

² Available with special catalog number only (consult factory).

³ 2 pole protector required (with one per power line) for 125 / 250 VAC. 1 pole protector required for 125 VAC 1 phase power system

Table D: Lists UL Listed configurations and performance capabilities as Circuit Breakers for use in Communications Equipment

UL489A (Communications Equipment)				
Circuit Configuration	Voltage		Current Rating	Interrupting Capacity (Amps)
	Max Rating	Frequency	General Purpose Amps	without Backup Fuse
Series	80	DC	0.10 - 50 60 - 90 ¹	5000

Notes:

¹ Parallel Pole Construction

Agency Approvals

UL 1077	Component Recognition Program as Protectors Supplementary (Guide CCN/QVNU2, File E75596)
UL 508	Switches, Industrial Control (Guide CCN/NRNT2, File E148683)
UL 1500	Protectors, Supplementary for Marine Electrical & Fuel Systems (Guide PEQZ2, File E75596) Ignition Protection
UL 489A	Communications Equipment (Guide CCN/DITT, File E189195)
CSA Certified	Component Supplementary Protector under Class 3215 30, File 047848 0 000 CSA Standard C22.2 No. 235
TUV Certified	EN60934, under License No. R72103448
VDE Certified	EN60934, VDE 0642 under File No. 10537

Ordering Scheme

Handle - UL 1077 Recognized

Sample Part Number

A A 3 - B 0 - 10 - 450 - 1 B 1 - C

Selection 1 2 3 4 5 6 7 8 9 10 11

1. SERIES

A

2. ACTUATOR ¹

A	Handle, one per pole
B	Handle, one per multipole unit
S	Mid-Trip Handle, one per pole
T	Mid-Trip Handle, one per pole & Alarm Switch

3. POLES

1	One	3	Three	5	Five
2	Two	4	Four	6	Six

4. CIRCUIT

A ²	Switch Only (No Coil)	F ³	Relay Trip (Current)
B	Series Trip (Current)	G ³	Relay Trip (Voltage)
C	Series Trip (Voltage)	H ^{3,4}	Dual Coil with Shunt Trip Voltage Coil
D ³	Shunt Trip (Current)	K ^{3,4}	Dual Coil with Relay Trip Voltage Coil
E ³	Shunt Trip (Voltage)		

5. AUXILIARY / ALARM SWITCH ⁵

0	without Aux Switch	7	S.P.S.T., 0.110 Q.C. Term. (Gold Contacts)
1	S.P.D.T., 0.093 Q.C. Term.	8	S.P.S.T., 0.187 Q.C. Term.
2	S.P.D.T., 0.110 Q.C. Term.	9	S.P.D.T., 0.187 Q.C. Term.
5	S.P.S.T., 0.093 Q.C. Term. (Gold Contacts)		

6. FREQUENCY & DELAY

03	DC 50/60Hz, Switch Only	31	DC, 50/60Hz Ultra Short
10	DC Instantaneous	32	DC, 50/60Hz Short
11	DC Ultra Short	34	DC, 50/60Hz Medium
12	DC Short	36	DC, 50/60Hz Long
14	DC Medium	42 ⁷	50/60Hz Short, High-inrush
16	DC Long	44 ⁷	50/60Hz Medium, High-inrush
20	50/60Hz Instantaneous	46 ⁷	50/60Hz Long, High-inrush
21	50/60Hz Ultra Short	52 ⁷	DC, Short, High-inrush
22	50/60Hz Short	54 ⁷	DC, Medium, High-inrush
24	50/60Hz Medium	56 ⁷	DC, Long, High-inrush
26	50/60Hz Long		
30	DC, 50/60Hz Instantaneous		

Notes:

- Actuator Code:
 - A: Handle tie pin spacer(s) and retainers provided un-assembled with multi-pole units.
 - B: Handle location as viewed from front of breaker:
 - 2 pole - left pole 3 pole - center pole 4 pole - two handles at center poles
 - 5 pole - three handles at center poles 6 pole - four handles at center poles
 - S: Handle moves to mid-position only upon electrical trip of the breaker. Available with circuit codes B, C, D, E, F, G, H and K.
 - T: Handle moves to mid-position and alarm switch activates only upon electrical trip of the breaker. Available with circuit codes B & C.
- Switch Only circuits, rated up to 50 amps and 6 poles, and only available when tied to a protected pole (Circuit Code B, C, D or H). For .02 to 30 amps, select Current Code 630. For 35 - 50 amps, select Current Code 650.
- Available with terminal Codes 1, 2 and 3. Current Rating limited to 50A amps maximum.
- Consult factory for available Dual Coil options, as special catalog number is required. With Shunt construction, Dual Coils will trip instantaneously on line voltage. Dual coils require 30VA minimum power to trip and are rated for intermittent duty only.
- Auxiliary Switch breakers with Series Trip & Switch Only circuits: ≤ 30A - supplied with standard half shells. 35-50A - supplied with extended boat (B-Style) half shells. On multi-pole breakers, one auxiliary switch is supplied, mounted in the extreme right pole.
- Separate pole type voltage coils not rated for continuous duty. Available only with delay codes 10 and 20.
- Available with Circuit Codes B & D only. VDE Certified to 30 amps. UL Recognized, CSA Accepted & TUV Certified to 50 amps.
- VDE Certification available with single pole breakers with DC Delay only. UL Recognition and CSA Accepted available in one and two pole breakers.
- Screw Terminals are recommended on ratings greater than 20 amps. Ratings over 30 amps are only available with Terminal Codes 5, 9, G, H, M and Q.
- Terminal Code I: VDE Certification up to 25 amps and UL Recognition and CSA Certification up to 30 amps, but not recommended over 20 amps.
- Terminal Codes 3, 5, E and H (Bus Type) with VDE, are supplied with Lock Washers, and Terminal Code M (M6 Threaded Stud) with VDE is supplied with Lock and Flat Washers. These breakers are only VDE Certified when the washers are used.
- Terminal Code L: VDE Certified available up to 12A. UL Recognized & CSA Accepted available up to 30A.
- Single pole breakers with Terminal Code P (Printed Circuit Board) are available up to 30 amps with VDE Certification and 50 amps with UL Recognition and CSA Accepted, with Circuit Codes A, B and C. Two pole breakers with Terminal Code P (Printed Circuit Board) are available up to 40 amps with UL Recognition and CSA Accepted with Circuit Codes A, B and C.
- Terminal Code Q not available with VDE certification.
- Single pole only.

7. CURRENT RATING (AMPERES)

CODE	AMPERES						
020	0.020	225	0.250	420	2.000	611	11.000
025	0.025	230	0.300	522	2.250	711	11.500
030	0.030	235	0.350	527	2.750	612	12.000
035	0.035	240	0.400	430	3.000	712	12.500
040	0.040	245	0.450	435	3.500	613	13.000
045	0.045	250	0.500	440	4.000	614	14.000
050	0.050	255	0.550	445	4.500	615	15.000
055	0.055	260	0.600	450	5.000	616	16.000
060	0.060	265	0.650	455	5.500	617	17.000
065	0.065	270	0.700	460	6.000	618	18.000
070	0.070	275	0.750	465	6.500	620	20.000
075	0.075	280	0.800	470	7.000	622	22.000
080	0.080	285	0.850	475	7.500	624	24.000
085	0.085	290	0.900	480	8.000	625	25.000
090	0.090	295	0.950	485	8.500	630	30.000
095	0.095	410	1.000	490	9.000	635 ⁸	35.000
210	0.100	512	1.250	495	9.500	640 ⁸	40.000
215	0.150	415	1.500	610	10.000	645 ⁸	45.000
220	0.200	517	1.750	710	10.500	650 ⁸	50.000

OR VOLTAGE COIL (NORMAL RATED VOLTAGE) ⁶

A06	6 DC	A32	32 DC	J12	12 AC	J65	65 AC
A12	12 DC	A48	48 DC	J18	18 AC	K20	120 AC
A18	18 DC	A65	65 DC	J24	24 AC	L40	240 AC
A24	24 DC	J06	6 AC	J48	48 AC		

8. TERMINAL ⁹

1 ¹⁰	Push-On 0.250 Tab (Q.C.)	B	Screw M5 with upturned lugs
2	Screw 8-32 with upturned lugs	C	Screw, M4 with upturned lugs
3 ¹¹	Screw 8-32 (Bus Type)	E ¹¹	Screw M4 (Bus Type)
4	Screw 10-32 with upturned lugs	F	Screw M5 with upturned lugs & 30° bend
5 ¹¹	Screw 10-32 (Bus Type)	G	Screw M5 (Bus Type) & 30° bend
6	Screw 8-32 with upturned lugs & 30° bend	H ¹¹	Screw M5 (Bus Type)
7	Screw 8-32 (Bus Type) & 30° bend	L ¹²	0.250 Q.C./ Solder Lug
8	Screw 10-32 with upturned lugs & 30° bend	M ¹¹	M6 Threaded Stud
9	Screw 10-32 (Bus Type) & 30° bend	P ¹³	Printed Circuit Board Terminals
		Q ¹⁴	Push-In Stud
		R	Screw, M4 with upturned lugs & 30° Bend
		S ¹³	Push-On 0.110 Tab (Q.C.)
		T ¹¹	Screw, M4 with upturned lugs

9. ACTUATOR COLOR & LEGEND

Actuator Color	I-O	ON-OFF	Dual	Legend
White	A	B	1	Black
Black	C	D	2	White
Red	F	G	3	White
Green	H	J	4	White
Blue	K	L	5	White
Yellow	M	N	6	Black
Gray	P	Q	7	Black
Orange	R	S	8	Black
Black (short handle) ¹⁵	T	U	9	White

10. MOUNTING / BARRIERS

	MOUNTING STYLE	BARRIERS
	Threaded Insert, 2 per pole	
1	6-32 x 0.195 inches	no
A	6-32 x 0.195 inches	yes
2	ISO M3 x 5mm	no
B	ISO M3 x 5mm (multipole only)	yes
	Front panel Snap-In, 0.75" wide bezel	
5	without Handleguard	no
6	without Handleguard (multipole only)	yes
	Front panel Snap-In, 0.96" wide bezel	
7	without Handleguard, 1-pole 0.96" wide;	no
	multipole units have .105" bezel overhang on all sides	
8	without Handleguard, 1-pole 0.96" wide;	yes
	(multipole only) .105" bezel overhang on all sides	

11. AGENCY APPROVAL

C	UL Recognized & CSA Accepted
D	VDE Certified, UL Recognized & CSA Accepted
E	TUV Certified, UL Recognized & CSA Accepted
I	UL Recognized STD 1077, UL Recognized 1500 (ignition protected), & CSA Accepted

Configure Complete Part Number >

Browse Standard Parts >

Ordering Scheme

Handle - UL 489A Listed

Sample Part Number

A A 1 - B 0 - 14 - 450 - 1 B 1 - M T

Selection 1 2 3 4 5 6 7 8 9 10 11 12

1. SERIES

A

2. ACTUATOR ¹

A Handle, one per pole
S Mid-Trip Handle, one per pole
T Mid-Trip Handle, one per pole & Alarm Switch

3. POLES ²

1 One 3 Three
2 Two 4 Four

4. CIRCUIT

B Series Trip (Current)

5 AUXILIARY/ALARM SWITCH ²

0 without Aux Switch 7 S.P.S.T., 0.110 Q.C. Term.
1 S.P.D.T., 0.093 Q.C. Term. (Gold Contacts)
2 S.P.D.T., 0.110 Q.C. Term. 8 S.P.S.T., 0.187 Q.C. Term.
5 S.P.S.T., 0.093 Q.C. Term. (Gold Contacts) 9 S.P.D.T., 0.187 Q.C. Term.

6. FREQUENCY & DELAY

11 DC Ultra Short 52³ DC, Short, High-inrush
12 DC Short 54³ DC, Medium, High-inrush
14 DC Medium 56³ DC, Long, High-inrush
16 DC Long

7. CURRENT RATING (AMPERES)

CODE	AMPERES						
210	0.100	285	0.850	455	5.500	613	13.000
215	0.150	290	0.900	460	6.000	614	14.000
220	0.200	295	0.950	465	6.500	615	15.000
225	0.250	410	1.000	470	7.000	616	16.000
230	0.300	512	1.250	475	7.500	617	17.000
235	0.350	415	1.500	480	8.000	618	18.000
240	0.400	517	1.750	485	8.500	620	20.000
245	0.450	420	2.000	490	9.000	622	22.000
250	0.500	522	2.250	495	9.500	624	24.000
255	0.550	527	2.750	610	10.000	625	25.000
260	0.600	430	3.000	710	10.500	630	30.000
265	0.650	435	3.500	611	11.000	635 ³	35.000
270	0.700	440	4.000	711	11.500	640 ³	40.000
275	0.750	445	4.500	612	12.000	645 ³	45.000
280	0.800	450	5.000	712	12.500	650 ³	50.000

8. TERMINAL

1⁶ Push-On 0.250 Tab (Q.C.) 9 Screw 10-32 (Bus Type) & 30° bend
2 Screw 8-32 with upturned lugs B Screw M5 with upturned lugs
3⁷ Screw 8-32 (Bus Type) F Screw M5 with upturned lugs & 30° bend
4 Screw 10-32 with upturned lugs G Screw M5 (Bus Type) & 30° bend
5⁷ Screw 10-32 (Bus Type) H Screw M5 (Bus Type)
6 Screw 8-32 with upturned lugs & 30° bend M⁷ M6 Threaded Stud
7 Screw 8-32 (Bus Type) P⁸ Printed Circuit Board Terminals
& 30° bend Q⁹ Push-In Stud & 30° bend
8 Screw 10-32 with upturned lugs & 30° bend

9. ACTUATOR COLOR & LEGEND

Actuator Color	ON-OFF	Dual	Legend Color
White	B	1	Black
Black	D	2	White
Red	G	3	White
Green	J	4	White
Blue	L	5	White
Yellow	N	6	Black
Gray	Q	7	Black
Orange	S	8	Black
Black (short handle) ¹⁰	U	9	White

10. MOUNTING / BARRIERS ⁹

MOUNTING STYLE	BARRIERS
Threaded Insert, 2 per pole	
1 6-32 x 0.195 inches	no
A 6-32 x 0.195 inches	yes
2 ISO M3 x 5mm	no
B ISO M3 x 5mm (multipole only)	yes
Front panel Snap-In, 0.75" wide bezel	
5 without Handleguard	no
6 without Handleguard (multipole only)	yes
Front panel Snap-In, 0.96" wide bezel	
7 without Handleguard, 1-pole 0.96" wide;	no
8 multipole units have .105" bezel overhang on all sides without Handleguard, 1-pole 0.96" wide;	yes
(multipole only) .105" bezel overhang on all sides	

11. MAXIMUM APPLICATION RATING

M 80 DC

12. AGENCY APPROVAL

T UL489A Listed
K UL489A Listed, VDE Certified
J UL489A Listed, TUV Certified

Notes:

- Actuator Code:
A: Handle tie pin spacer(s) and retainers provided un-assembled with multi-pole units.
S: Handle moves to mid-position only upon electrical trip of the breaker.
T: Handle moves to mid-position and alarm switch activates only upon electrical trip of the breaker.
- On multi-pole breakers, one auxiliary switch is supplied, mounted in the extreme right pole.
- VDE Certified to 30 amps. UL489A Listed to 50 amps.
- VDE Certification available with single pole breakers only. UL489A Listing available with one and two pole breakers.
- Screw Terminals are recommended on ratings greater than 20 amps. Ratings over 30 amps are only available with Terminal Codes 5, 9, G, H, M and Q.
- Terminal Code 1 (Push-On) available up to 25 amps with VDE Certification and 30 amps with UL489A Listing, but is not recommended over 20 amps.
- Terminal Codes 3, 5 and H (Bus Type) with VDE, are supplied with Lock Washers, and Terminal Code M (M6 Threaded Stud) with VDE is supplied with Lock and Flat Washers. These breakers are only VDE Certified when the washers are used.
- Single pole breakers with Terminal Code P (Printed Circuit Board) are available up to 30 amps with VDE Certification and 50 amps with UL489A Listing.
- Terminal Code Q not available with VDE certification.
- Single pole only.

[Configure Complete Part Number >](#)

[Browse Standard Parts >](#)

Ordering Scheme

Handle - World

Sample Part Number

A A 3 - B 0 - 14-450 - 1 A 1 - P

Selection

1 2 3 4 5 6 7 8 9 10 11

1. SERIES

A

2. ACTUATOR ¹

- A Handle, one per pole
- B Handle, one per multipole unit
- S Mid-Trip Handle, one per pole
- T Mid-Trip Handle, one per pole & Alarm Switch

3. POLES

- | | | |
|-------|---------|--------|
| 1 One | 3 Three | 5 Five |
| 2 Two | 4 Four | 6 Six |

4. CIRCUIT

- | | |
|--------------------------------------|---|
| A ² Switch Only (No Coil) | D ³ Shunt Trip (Current) |
| B Series Trip (Current) | E ³ Shunt Trip (Voltage) |
| C Series Trip (Voltage) | H ^{3,4} Dual Coil with Shunt Trip Voltage Coil |

5. AUXILIARY / ALARM SWITCH ⁵

- 0 without Aux Switch
- 2 S.P.D.T., 0.110 Q.C. Term.

6. FREQUENCY & DELAY

- | | |
|----------------------------|---|
| 03 DC 50/60Hz, Switch Only | 30 DC, 50/60Hz Instantaneous |
| 10 DC Instantaneous | 31 DC, 50/60Hz Ultra Short |
| 11 DC Ultra Short | 32 DC, 50/60Hz Short |
| 12 DC Short | 34 DC, 50/60Hz Medium |
| 14 DC Medium | 36 DC, 50/60Hz Long |
| 16 DC Long | 42 ⁷ 50/60Hz Short, High-inrush |
| 20 50/60Hz Instantaneous | 44 ⁷ 50/60Hz Medium, High-inrush |
| 21 50/60Hz Ultra Short | 46 ⁷ 50/60Hz Long, High-inrush |
| 22 50/60Hz Short | 52 ⁷ DC, Short, High-inrush |
| 24 50/60Hz Medium | 54 ⁷ DC, Medium, High-inrush |
| 26 50/60Hz Long | 56 ⁷ DC, Long, High-inrush |

7. CURRENT RATING (AMPERES)

CODE	AMPERES	
210	0.100	285 0.850
215	0.150	290 0.900
220	0.200	295 0.950
225	0.250	410 1.000
230	0.300	512 1.250
235	0.350	415 1.500
240	0.400	517 1.750
245	0.450	420 2.000
250	0.500	522 2.250
255	0.550	527 2.750
260	0.600	430 3.000
265	0.650	435 3.500
270	0.700	440 4.000
275	0.750	445 4.500
280	0.800	450 5.000
455	5.500	613 13.000
460	6.000	614 14.000
465	6.500	615 15.000
470	7.000	616 16.000
475	7.500	617 17.000
480	8.000	618 18.000
485	8.500	620 20.000
490	9.000	622 22.000
495	9.500	624 24.000
610	10.000	625 25.000
710	10.500	630 30.000
611	11.000	635 ⁸ 35.000
711	11.500	640 ⁸ 40.000
612	12.000	645 ⁸ 45.000
712	12.500	650 ⁸ 50.000

OR VOLTAGE COIL (NORMAL RATED VOLTAGE) ⁶

A06 6 DC	A32 32 DC	J12 12 AC	J65 65 AC
A12 12 DC	A48 48 DC	J18 18 AC	K20 120 AC
A18 18 DC	A65 65 DC	J24 24 AC	L40 240 AC
A24 24 DC	J06 6 AC	J48 48 AC	

8. TERMINAL

- | | |
|---|--|
| 1 ¹⁰ Push-On 0.250 Tab (Q.C.) | 9 Screw 10-32 (Bus Type) & 30° bend |
| 2 Screw 8-32 with upturned lugs | B Screw M5 with upturned lugs |
| 3 ¹¹ Screw 8-32 (Bus Type) | C Screw, M4 with upturned lugs |
| 4 Screw 10-32 with upturned lugs | E ¹¹ Screw M4 (Bus Type) |
| 5 ¹¹ Screw 10-32 (Bus Type) | F Screw M5 with upturned lugs & 30° bend |
| 6 Screw 8-32 with upturned lugs & 30° bend | G Screw M5 (Bus Type) & 30° bend |
| 7 Screw 8-32 (Bus Type) & 30° bend | H ¹¹ Screw M5 (Bus Type) |
| 8 Screw 10-32 with upturned lugs & 30° bend | M M6 Threaded Stud |
| | R Screw, M4 with upturned lugs & 30° Bend |
| | T ¹¹ Screw, M4 with upturned lugs |

9 ACTUATOR COLOR & LEGEND

Actuator Color	I-O	Dual	Legend Color
White	A	1	Black
Black	C	2	White
Red	F	3	White
Green	H	4	White
Blue	K	5	White
Yellow	M	6	Black
Gray	P	7	Black
Orange	R	8	Black
Black (short handle) ⁵	T	9	White

10. MOUNTING / BARRIERS

MOUNTING STYLE	BARRIERS
Threaded Insert, 2 per pole	
1 6-32 x 0.195 inches	no
A 6-32 x 0.195 inches	yes
2 ISO M3 x 5mm	no
B ISO M3 x 5mm (multipole only)	yes
Front panel Snap-In, 0.75" wide bezel	
5 without Handleguard	no
6 without Handleguard (multipole only)	yes
Front panel Snap-In, 0.96" wide bezel	
7 without Handleguard, 1-pole 0.96" wide;	no
8 multipole units have .105" bezel overhang on all sides without Handleguard, 1-pole 0.96" wide;	yes
(multipole only) .105" bezel overhang on all sides	

11. AGENCY APPROVAL

- P TUV Certified, UL Recognized & CSA Accepted
- Q UL Recognized STD 1077, UL Recognized 1500 (ignition protected), & CSA Accepted

Notes:

- 1 Actuator Code:
A: Handle tie pin spacer(s) and retainers provided unassembled with multi-pole units.
S: Handle moves to mid-position only upon electrical trip of the breaker. Available with circuit codes B, C, D, E, and H.
T: Handle moves to mid-position and alarm switch activates only upon electrical trip of the breaker. Available with circuit codes B & C.
- 2 Switch Only circuits, rated up to 50 amps and 6 poles, and only available when tied to a protected pole (Circuit Code B, C, D or H). For .01 to 30 amps, select Current Code 630. For 35 - 50 amps, select Current Code 650.
- 3 Available with terminal Codes 1, 2 and 3. Current Rating limited to 30 amps maximum.
- 4 Consult factory for available Dual Coil options, as special catalog number is required. With Shunt construction, Dual Coils will trip instantaneously on line volt age. Dual coils require 30VA minimum power to trip and are rated for intermittent duty only.
- 5 On multi-pole breakers, one auxiliary switch is supplied, mounted in the extreme right pole.
- 6 Separate pole type voltage coils not rated for continuous duty. Available only with delay codes 10, 20 & 30.
- 7 Available with Circuit Codes B & D only. VDE Certified to 30 amps. UL Recognized, CSA Accepted & TUV Certified to 50 amps.
- 8 Available up to two poles with AC or DC delays.
- 9 Screw Terminals are recommended on ratings greater than 20 amps. Ratings over 30 amps are only available with Terminal Codes 5, 9, G and H.
- 10 Terminal Code I: TUV Certification up to 30 amps, but not recommended over 20 amps.
- 11 Terminal Codes 3, 5, 7, 9, E, G and H (Bus Type) are supplied with Lock Washers. These breakers are only TUV Certified when the washers are used.
- 12 Single pole only.

[Configure Complete Part Number >](#)

[Browse Standard Parts >](#)

Circuit & Terminal Diagrams Handle

inches [millimeters]

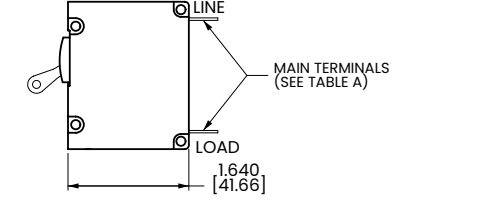
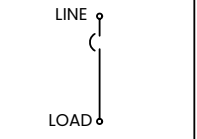
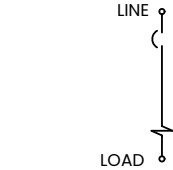
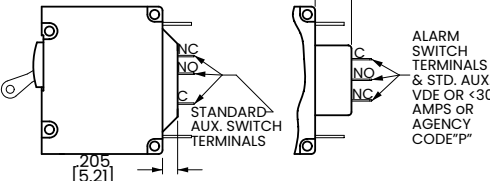
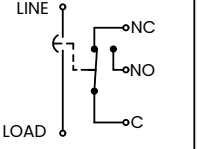
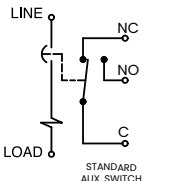
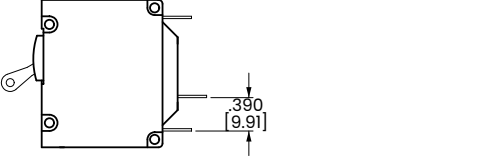
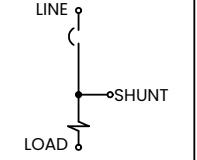
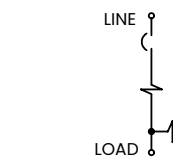
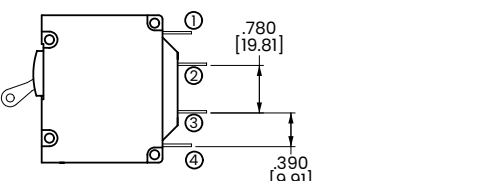
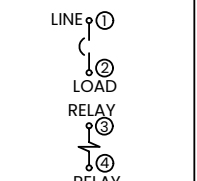
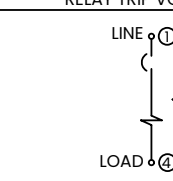
CIRCUIT BREAKER PROFILE	CIRCUIT SCHEMATIC		CIRCUIT SCHEMATIC	
	ANSI	CIRCUIT CODE	ANSI	CIRCUIT CODE
2 TERMINALS 	SWITCH ONLY (NO COIL) 	ANSI SERIES TRIP 	BC 0	BC 0
5 TERMINALS 	SWITCH ONLY (NO COIL) WITH AUXILIARY SWITCH 	SERIES TRIP WITH (3) AUXILIARY/ALARM SWITCH 	A 1 2 3 4	BC 1 2 3 4
3 TERMINALS 	SHUNT TRIP 	DUAL COIL; SERIES TRIP CURRENT COIL, RELAY TRIP VOLTAGE COIL 	DE 0	H 0
4 TERMINALS 	RELAY TRIP 	DUAL COIL; SERIES TRIP CURRENT COIL, RELAY TRIP VOLTAGE COIL 	FG 0	K 0

AUXILIARY/ALARM SWITCH TERMINAL DETAIL

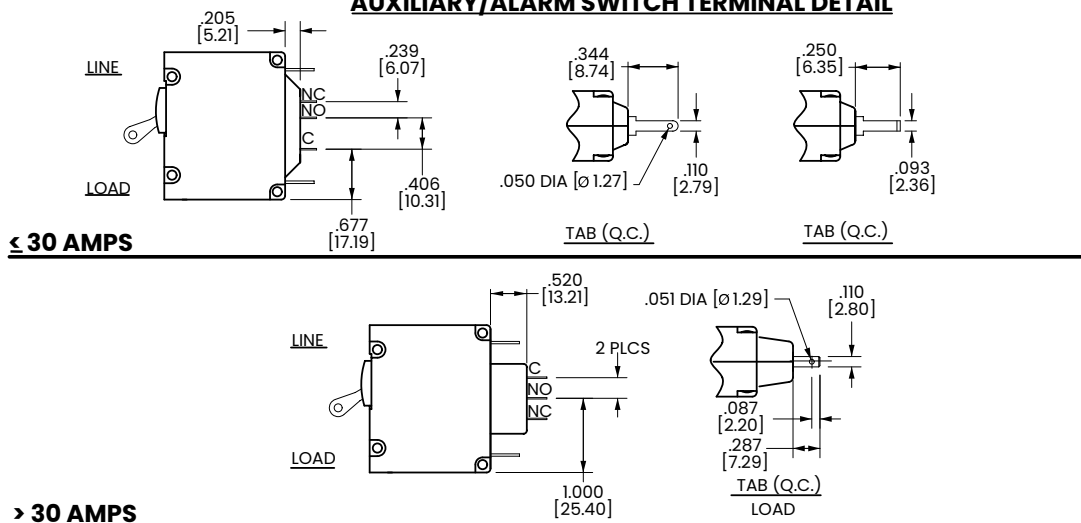

- Notes:
 1 Tolerance $\pm .020$ [51] unless otherwise specified.
 2 Alarm Switch available with .110 x .020 Q.C. & Solder Lug Terminals Only.

Circuit & Terminal Diagrams Handle

inches [millimeters]

HANDLE POSITION VS. AUX/ALARM SWITCH MODE						
CIRCUIT BREAKER MODE	STANDARD C/B		MID TRIP C/B		MID TRIP C/B	
	HANDLE POSITION	AUX. SWITCH MODE	HANDLE POSITION	ALARM SWITCH MODE	HANDLE POSITION	AUX. SWITCH CODE (W/O ALARM SWITCH)
OFF						
ON						
ELECTRICAL TRIP						

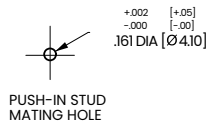
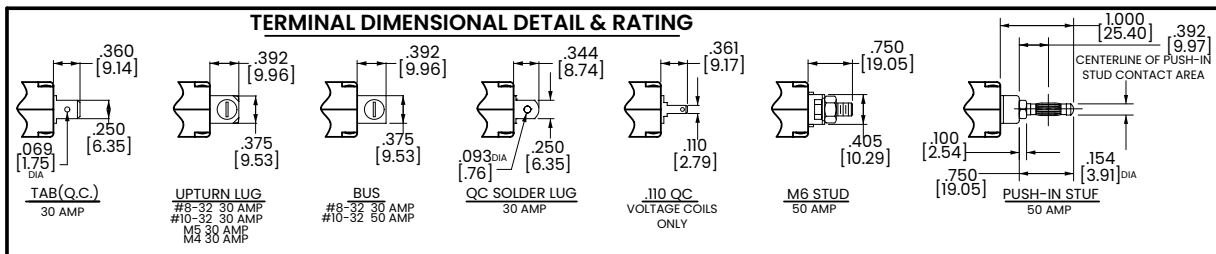

TABLE A TIGHTENING TORQUE SPECIFICATIONS

THREAD SIZE	TORQUE
#8-32 & M3 MOUNTING HARDWARE	7-9 IN-LBS [0.8-1.0 NM]
#8-32 & M4 THREAD TERMINAL SCREW	12-15 IN-LBS [1.4-1.7 NM]
#10-32 & M5 THREAD TERMINAL SCREW	15-20 IN-LBS [1.7-2.3 NM]

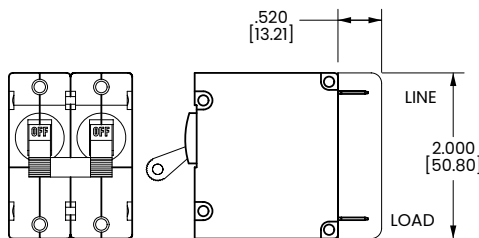
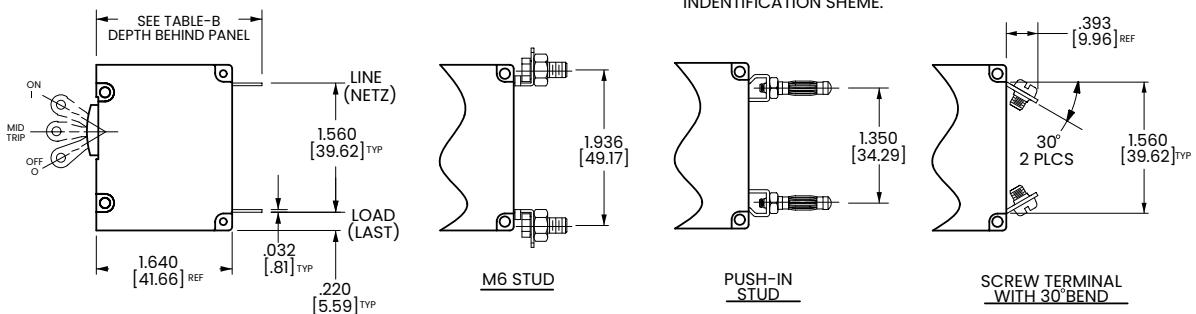

TABLE B

TERMINAL DESCRIPTION		DEPTH BEHIND PANEL
MAIN	TAB (Q.C.)	2.000 [50.80]
	SCREW TYPE	2.032 [51.60]
SHUNT, RELAY & DUAL COIL	TAB (Q.C.)	2.207 [56.10]
	SCREW #8-32 W/UPTURNED LUGS	2.364 [60.05]
AUX. SWITCH*	.093 TAB (Q.C.)	2.095 [53.20]
	.110 TAB (Q.C.)	2.189 [55.60]
	SOLDER TYPE	1.970 [50.00]

*AVAILABLE ON SERIES TRIP AND SWITCH ONLY CIRCUITS WHEN CALLED FOR ON MULTI-POLE UNITS. ONLY ONE AUX. SWITCH IS NORMALLY SUPPLIED, AS SHOWN IN MULTI-POLE IDENTIFICATION SCHEME.



- Notes:
- 1 Tolerance $\pm .020$ [.51] unless otherwise specified.
 - 2 Alarm Switch available with .110 x .020 QC & solder lug terminals only.

Dimensional Specs Handle

inches [millimeters]

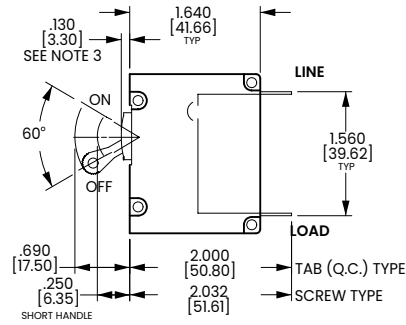
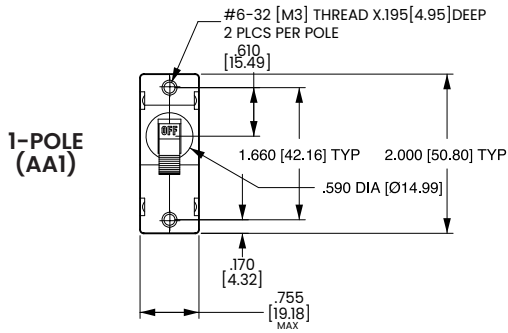

TAB (Q.C.) TYPE TERMINALS IN SERIES TRIP CONCUIT CONFIGURATION SHOWN. FOR OTHER CONFIGURATIONS SEE CIRCUIT & TERMINAL DIAGRAMS

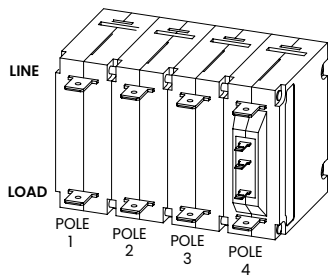
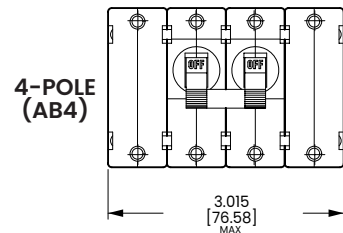
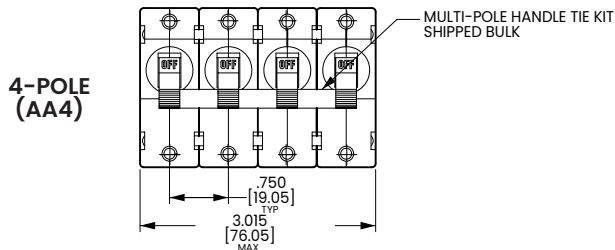
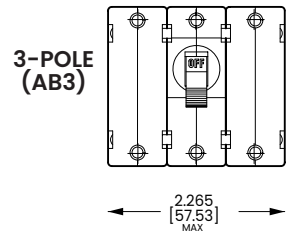
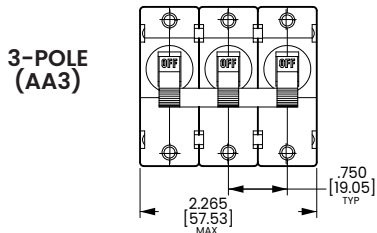
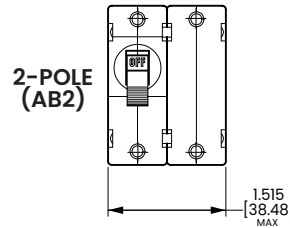
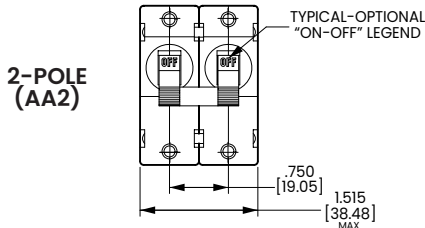

MULTI-POLE IDENTIFICATION SCHEME AS VIEWED FROM TERMINAL END OF BREAKER.

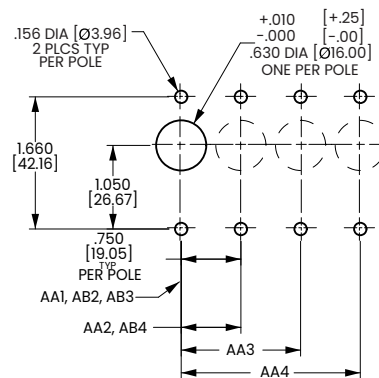

PANEL CUTOUT DETAIL
TOLERANCE ±.005[±.12] UNLESS OTHERWISE SPECIFIED

Notes:

- 1 Tolerance ± 0.20 [.51] unless otherwise specified.
- 2 For agency code P = .150 [3.81].

Dimensional Specs Handle

inches [millimeters]

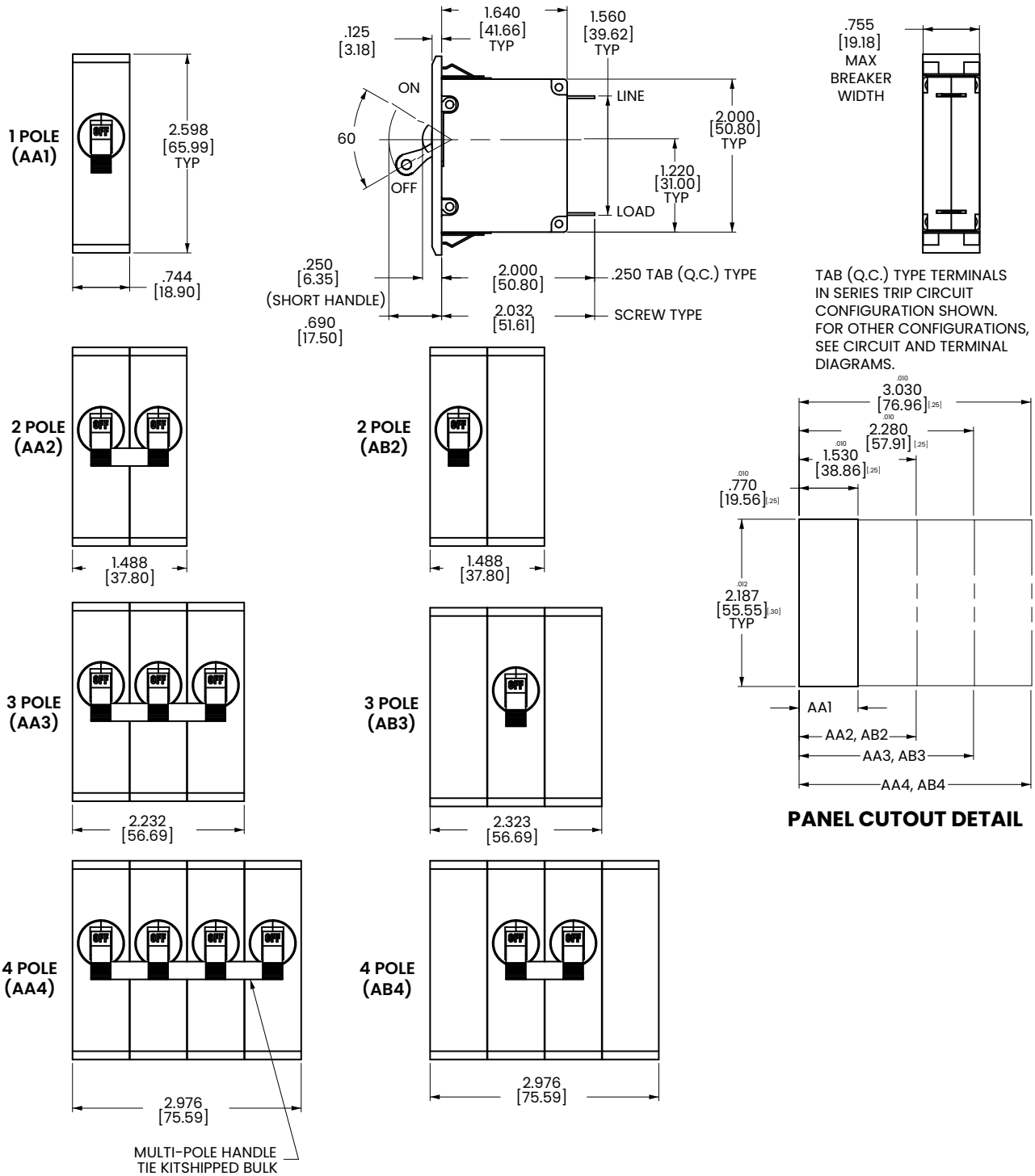

TAB (Q.C.) TYPE TERMINALS IN SERIES TRIP CIRCUIT CONFIGURATION SHOWN. FOR OTHER CONFIGURATIONS, SEE CIRCUIT AND TERMINAL DIAGRAMS.

Notes:
 1 Recommended panel thickness: .040 [1.02] to .100 [2.54].
 2 Tolerance ±.020 [.51] unless otherwise specified.

Dimensional Specs Handle

inches [millimeters]

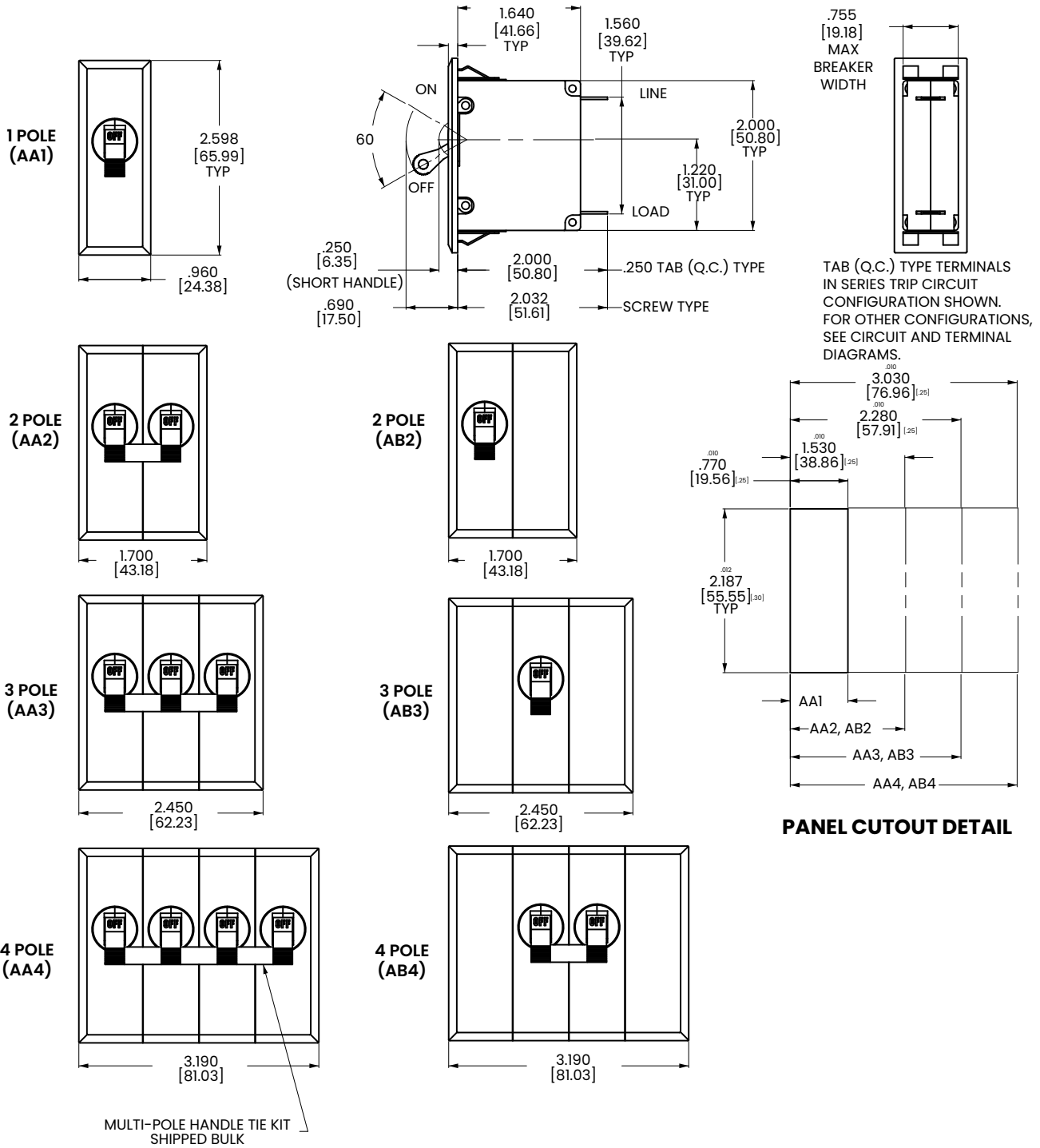

Notes:
 1 Recommended panel thickness: .040 [1.02] to .100 [2.54].
 2 Tolerance ±.020 [.51] unless otherwise specified.

Ordering Scheme

Sealed Toggle

Sample Part Number

A M 1 - B 0 - 10 - 450 - 1 0 1 - C

Selection

1 2 3 4 5 6 7 8 9 10 11

1. SERIES

A

2. ACTUATOR ¹

M Sealed Toggle, one per unit

3. POLES

1 One 2 Two 3 Three

4. CIRCUIT

A ²	Switch Only (No Coil)	F ³	Relay Trip (Current)
B	Series Trip (Current)	G ³	Relay Trip (Voltage)
C	Series Trip (Voltage)	H ^{3,4}	Dual Coil with Shunt Trip Voltage Coil
D ³	Shunt Trip (Current)	K ^{3,4}	Dual Coil with Relay Trip Voltage Coil
E ³	Shunt Trip (Voltage)		

5. AUXILIARY / ALARM SWITCH ⁵

0	without Aux Switch	7	S.P.S.T., 0.110 Q.C. Term. (Gold Contacts)
1	S.P.D.T., 0.093 Q.C. Term.	8	S.P.S.T., 0.187 Q.C. Term.
2	S.P.D.T., 0.110 Q.C. Term.	9	S.P.D.T., 0.187 Q.C. Term. (Gold Contacts)
5	S.P.S.T., 0.093 Q.C. Term. (Gold Contacts)		

6. FREQUENCY & DELAY

03	DC 50/60Hz, Switch Only	30	DC, 50/60Hz Instantaneous
10	DC Instantaneous	31	DC, 50/60Hz Ultra Short
11	DC Ultra Short	32	DC, 50/60Hz Short
12	DC Short	34	DC, 50/60Hz Medium
14	DC Medium	36	DC, 50/60Hz Long
16	DC Long	42 ⁷	50/60Hz Short, High-inrush
20	50/60Hz Instantaneous	44 ⁷	50/60Hz Medium, High-inrush
21	50/60Hz Ultra Short	46 ⁷	50/60Hz Long, High-inrush
22	50/60Hz Short	52 ⁷	DC, Short, High-inrush
24	50/60Hz Medium	54 ⁷	DC, Medium, High-inrush
26	50/60Hz Long	56 ⁷	DC, Long, High-inrush

7. CURRENT RATING (AMPERES)

CODE	AMPERES						
020	0.020	230	0.300	425	2.500	612	12.000
025	0.025	235	0.350	527	2.750	712	12.500
030	0.030	240	0.400	430	3.000	613	13.000
035	0.035	245	0.450	435	3.500	614	14.000
040	0.040	250	0.500	440	4.000	615	15.000
045	0.045	255	0.550	445	4.500	616	16.000
050	0.050	260	0.600	450	5.000	617	17.000
055	0.055	265	0.650	455	5.500	618	18.000
060	0.060	270	0.700	460	6.000	620	20.000
065	0.065	275	0.750	465	6.500	622	22.000
070	0.070	280	0.800	470	7.000	624	24.000
075	0.075	285	0.850	475	7.500	625	25.000
080	0.080	290	0.900	480	8.000	630	30.000
085	0.085	295	0.950	485	8.500	635 ⁸	35.000
090	0.090	410	1.000	490	9.000	640 ⁸	40.000
095	0.095	512	1.250	495	9.500	645 ⁸	45.000
210	0.100	415	1.500	610	10.000	650 ⁸	50.000
215	0.150	517	1.750	710	10.500		
220	0.200	420	2.000	611	11.000		
225	0.250	522	2.250	711	11.500		

OR VOLTAGE COIL (NORMAL RATED VOLTAGE) ⁶

A06	6 DC	A32	32 DC	J12	12 AC	J65	65 AC
A12	12 DC	A48	48 DC	J18	18 AC	K20	120 AC
A18	18 DC	A65	65 DC	J24	24 AC	L40	240 AC
A24	24 DC	J06	6 AC	J48	48 AC		

8. TERMINAL ⁹

1 ¹⁰	Push-On 0.250 Tab (Q.C.)	C	Screw, M4 with upturned lugs
2	Screw 8-32 with upturned lugs	E	Screw M4 (Bus Type)
3	Screw 8-32 (Bus Type)	F	Screw M5 with upturned lugs & 30° bend
4	Screw 10-32 with upturned lugs	G	Screw M5 (Bus Type) & 30° bend
5	Screw 10-32 (Bus Type)	H	Screw M5 (Bus Type)
6	Screw 8-32 with upturned lugs & 30° bend	L ¹²	0.250 Q.C./ Solder Lug
7	Screw 8-32 (Bus Type) & 30° bend	M	M6 Threaded Stud
8	Screw 10-32 with upturned lugs & 30° bend	P ¹²	Printed Circuit Board Terminals
9	Screw 10-32 (Bus Type) & 30° bend	Q	Push-In Stud
B	Screw M5 with upturned lugs	R	Screw, M4 with upturned lugs & 30° Bend
		S ¹⁷	Push-On 0.110 Tab (Q.C.) & 30° bend
		T	Screw, M4 with upturned lugs

9. LEGEND PLATE

0 No legend plate

10. MOUNTING / BARRIERS

	MOUNTING STYLE	BARRIERS
1	Standard Hex Nut	no
A	Standard Hex Nut (multipole only)	yes

11. AGENCY APPROVAL

C UL Recognized & CSA Accepted
 I UL Recognized STD 1077, UL Recognized 1500 (ignition protected), & CSA Accepted

Notes:

- Actuator Code M: Handle location as viewed from front of panel: 2 pole - right pole 3 pole - center pole
- Switch Only circuits, rated up to 50 amps and 3 poles. Only available when tied to a protected pole. For .02 to 30 amps, select Current Code 630. For 35 - 50 amps, select Current Code 650.
- Available with terminal Codes 1, 2 and 3. Current Rating limited to 30 amps maximum.
- Consult factory for available Dual Coil options, as special catalog number is required. With Shunt construction, Dual Coils will trip instantaneously on line voltage. Dual coils require 30VA minimum power to trip and are rated for intermittent duty only.
- Auxiliary Switch available on Series Trip & Switch Only circuits, limited to 30 amps. On multi-pole breakers, one auxiliary switch is supplied, mounted in the extreme right pole.
- Voltage coils not rated for continuous duty. Available only with delay codes 10 and 20.
- Available with Circuit Codes B & D only. VDE Certified to 30 amps. UL Recognized, CSA Accepted & TUV Certified to 50 amps.
- UL Recognition and CSA Certification available on one and two pole breakers.
- Screw Terminals are recommended on ratings greater than 20 amps. Ratings over 30 amps are only available with Terminal Codes 5, 9, B, F, G, H, M and Q.
- Terminal Code I: UL Recognition and CSA Certification up to 30 amps, but not recommended over 20 amps.
- Terminal Code L: available up to 30A.
- Single pole breakers with Terminal Code P (Printed Circuit Board) are available up to 50 amps, with Circuit Codes A, B and C. Two pole breakers with Terminal Code P (Printed Circuit Board) are available up to 40 amps with Circuit Codes A, B and C.

[Configure Complete Part Number >](#)

[Browse Standard Parts >](#)

Dimensional Specs Sealed Toggle

inches [millimeters]

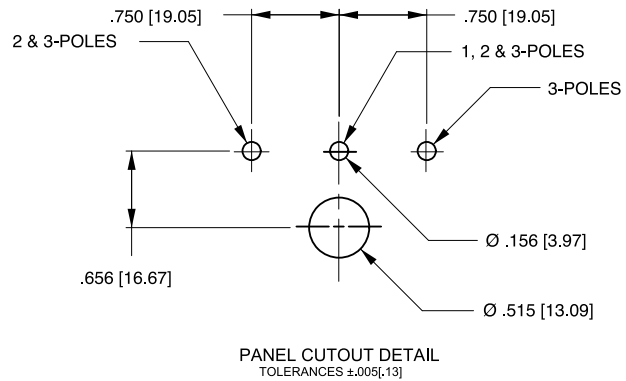
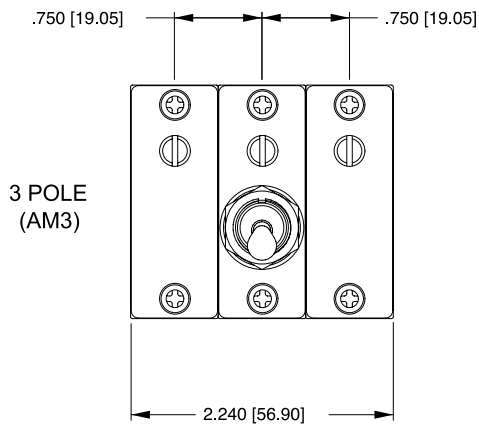
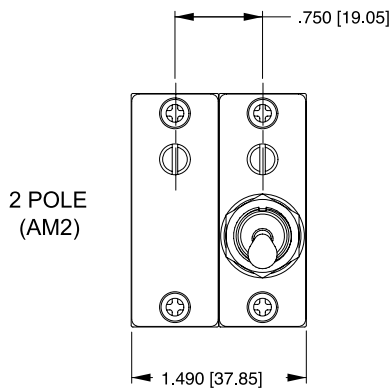
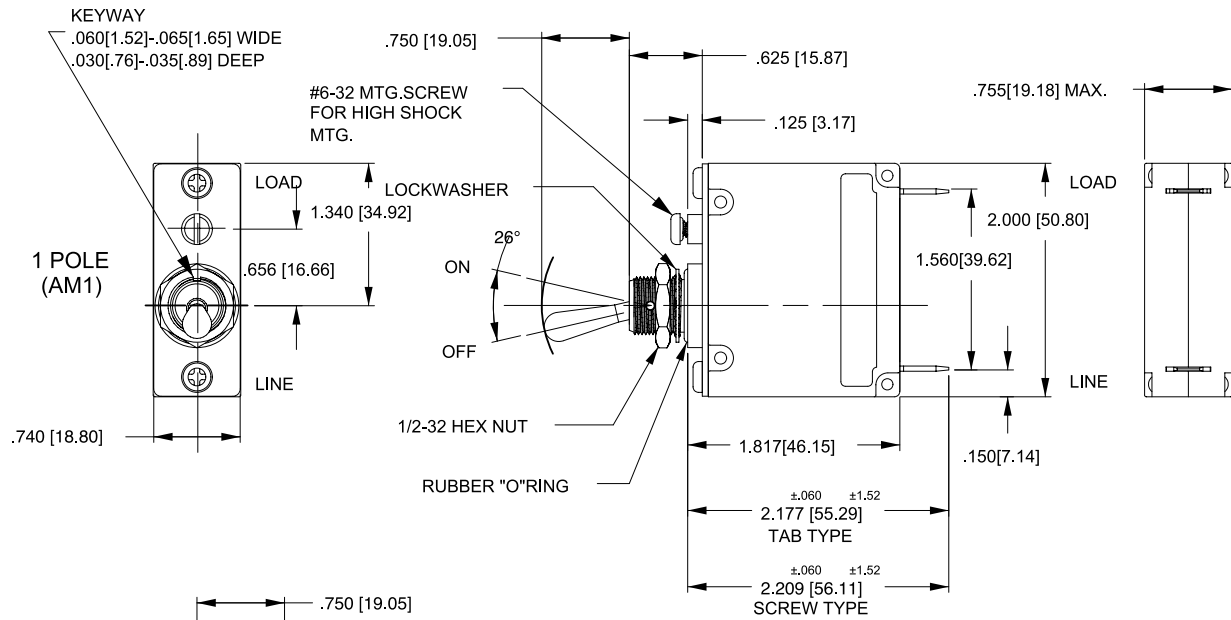

Notes:
 1 Tolerance ±.020 [.51] unless otherwise specified.

Ordering Scheme

Rocker UL 1077 Recognized

Sample Part Number

A F 1 - B 0 - 24-630 - 2 3 1 - D

Selection

1 2 3 4 5 6 7 8 9 10 11

1. SERIES

A

2. ACTUATOR ¹

Two Color Visi-Rocker

- C Indicate ON, vertical legend
- D Indicate ON, horizontal legend
- F Indicate OFF, vertical legend
- G Indicate OFF, horizontal legend
- H Indicate OFF, no legend

Push-To-Reset, Visi-Rocker

- N Indicate OFF, vertical legend
- O Indicate OFF, horizontal legend
- P Indicate OFF, no legend

Single color

- J Vertical legend
- K Horizontal legend
- L No legend

Push-To-Reset, Single color

- R Vertical legend
- U Horizontal legend
- V No legend

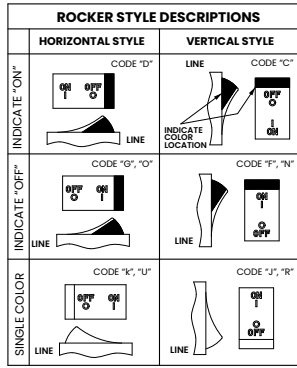

3. POLES

1 One 2 Two 3 Three

4. CIRCUIT

- | | |
|--------------------------------------|---|
| A ³ Switch Only (No Coil) | G ⁴ Relay Trip (Voltage) |
| B Series Trip (Current) | H ^{4,5} Dual Coil with Shunt Trip Voltage Coil |
| C Series Trip (Voltage) | K ^{4,5} Dual Coil with Relay Trip Voltage Coil |
| D ⁴ Shunt Trip (Current) | |
| E ⁴ Shunt Trip (Voltage) | |

5. AUXILIARY / ALARM SWITCH ⁵

- | | |
|--|--|
| 0 without Aux Switch | 7 S.P.S.T., 0.110 Q.C. Term. (Gold Contacts) |
| 1 S.P.D.T., 0.093 Q.C. Term. | 8 S.P.S.T., 0.187 Q.C. Term. |
| 2 S.P.D.T., 0.110 Q.C. Term. | 9 S.P.D.T., 0.187 Q.C. Term. |
| 5 S.P.S.T., 0.093 Q.C. Term. (Gold Contacts) | |

6. FREQUENCY & DELAY

- | | |
|----------------------------|---|
| 03 DC 50/60Hz, Switch Only | 30 DC, 50/60Hz Instantaneous |
| 10 DC Instantaneous | 31 DC, 50/60Hz Ultra Short |
| 11 DC Ultra Short | 32 DC, 50/60Hz Short |
| 12 DC Short | 34 DC, 50/60Hz Medium |
| 14 DC Medium | 36 DC, 50/60Hz Long |
| 16 DC Long | 42 ⁹ 50/60Hz Short, High-inrush |
| 20 50/60Hz Instantaneous | 44 ⁹ 50/60Hz Medium, High-inrush |
| 21 50/60Hz Ultra Short | 46 ⁹ 50/60Hz Long, High-inrush |
| 22 50/60Hz Short | 52 ⁹ DC, Short, High-inrush |
| 24 50/60Hz Medium | 54 ⁹ DC, Medium, High-inrush |
| 26 50/60Hz Long | 56 ⁹ DC, Long, High-inrush |

7. CURRENT RATING (AMPERES)

CODE	AMPERES						
020	0.020	225	0.250	420	2.000	611	11.000
025	0.025	230	0.300	522	2.250	711	11.500
030	0.030	235	0.350	527	2.750	612	12.000
035	0.035	240	0.400	430	3.000	712	12.500
040	0.040	245	0.450	435	3.500	613	13.000
045	0.045	250	0.500	440	4.000	614	14.000
050	0.050	255	0.550	445	4.500	615	15.000
055	0.055	260	0.600	450	5.000	616	16.000
060	0.060	265	0.650	455	5.500	617	17.000
065	0.065	270	0.700	460	6.000	618	18.000
070	0.070	275	0.750	465	6.500	620	20.000
075	0.075	280	0.800	470	7.000	622	22.000
080	0.080	285	0.850	475	7.500	624	24.000
085	0.085	290	0.900	480	8.000	625	25.000
090	0.090	295	0.950	485	8.500	630	30.000
095	0.095	410	1.000	490	9.000	635 ⁸	35.000
210	0.100	512	1.250	495	9.500	640 ⁸	40.000
215	0.150	415	1.500	610	10.000	645 ⁸	45.000
220	0.200	517	1.750	710	10.500	650 ⁸	50.000

OR VOLTAGE COIL (NORMAL RATED VOLTAGE) ⁸

A06 6 DC	A32 32 DC	J12 12 AC	J65 65 AC
A12 12 DC	A48 48 DC	J18 18 AC	K20 20 AC
A18 18 DC	A65 65 DC	J24 24 AC	L40 240 AC
A24 24 DC	J06 6 AC	J48 48 AC	

8. TERMINAL ¹¹

- | | |
|---|---|
| 1 ¹² Push-On 0.250 Tab (Q.C.) | C Screw, M4 with upturned lugs |
| 2 Screw 8-32 with upturned lugs | E ¹³ Screw M4 (Bus Type) |
| 3 ¹³ Screw 8-32 (Bus Type) | F Screw M5 with upturned lugs & 30° bend |
| 4 Screw 10-32 with upturned lugs | G Screw M5 (Bus Type) & 30° bend |
| 5 ¹³ Screw 10-32 (Bus Type) | H ¹³ Screw M5 (Bus Type) |
| 6 Screw 8-32 with upturned lugs & 30° bend | L ¹⁴ 0.250 Q.C./ Solder Lug |
| 7 Screw 8-32 (Bus Type) | M ¹³ M6 Threaded Stud |
| 8 Screw 10-32 with upturned lugs & 30° bend | P ¹⁵ Printed Circuit Board Terminals |
| 9 Screw 10-32 (Bus Type) | Q Push-In Stud |
| B Screw M5 with upturned lugs | R Screw, M4 with upturned lugs & 30° Bend |
| | S ¹⁷ Push-On 0.110 Tab (Q.C.) & 30° bend |
| | T Screw, M4 with upturned lugs |

9. ACTUATOR COLOR & LEGEND

Actuator or Visi-Color ¹²	Marking:			Marking Color	
	I-O	ON-OFF	Dual ¹²	Single Color	Visi-Rocker
White	A	B	1	Black	White
Black	C	D	2	White	n/a
Red	F	G	3	White	Red
Green	H	J	4	White	Green
Blue	K	L	5	White	Blue
Yellow	M	N	6	Black	Yellow
Gray	P	Q	7	Black	Gray
Orange	R	S	8	Black	Orange

10. MOUNTING / BARRIERS ²⁰

STANDARD ROCKER BEZEL Threaded Insert, 2 per pole	BARRIERS
1 6-32 x 0.195 inches	no
A 6-32 X 0.195 inches (multi-pole units only)	yes
2 ISO M3 x 5mm	no
B ISO M3 x 5mm (multi-pole units only)	yes
ROCKERGUARD & PUSH-TO-RESET BEZEL Threaded Insert, 2 per pole	
3 6-32 x 0.195 inches	no
C 6-32 x 0.195 inches (multi-pole units only)	yes
4 ISO M3 x 5mm	no
D ISO M3 x 5mm (multi-pole units only)	yes
FRONT PANEL SNAP-IN BRACKET, 0.744" [18.90mm] wide bezel	
8 without Rockerguard (single pole units only)	no
H with Rockerguard (single pole units only)	no
FRONT PANEL SNAP-IN BRACKET, 0.96" [24.48mm] wide bezel	
9 without Rockerguard (single pole units only)	no
J with Rockerguard (single pole units only)	no

11. AGENCY APPROVAL

- C UL Recognized & CSA Accepted
- D VDE Certified, UL Recognized & CSA Accepted
- E TUV Certified, UL Recognized & CSA Accepted
- I UL Recognized STD 1077, UL Recognized 1500 (ignition protected), & CSA Accepted

Notes:

- 1 Push-To-Reset actuators have OFF portion of rocker shrouded.
- 2 Multi-pole breakers have all breakers identical except when specifying Auxiliary switch and/or mixed poles, and have one rocker per breaker.
- 3 Switch Only circuits, rated up to 50 amps & 3 poles, are available only when tied to a protected pole (Circuit Code B, C, D or H). For .02 to 30 amps, select Current Code 630. For 35 - 50 amps, select Current Code 650.
- 4 Available with terminal Codes 1, 2 and 3. Current Rating limited to 30 amps maximum.
- 5 Consult factory for Dual Coil options, as special catalog number is required. With Shunt construction, Dual Coils will trip instantaneously on line voltage. Dual coils require 30VA minimum power to trip and are rated for intermittent duty only.
- 6 Auxiliary Switch breakers with Series Trip & Switch Only circuits: < 30A, are supplied with standard half shells. 30-50A are supplied with extended boat (B-Style) half shells.
- 7 On multi-pole breakers, one auxiliary switch is supplied, mounted in the right pole.
- 8 Separate pole type voltage coils not rated for continuous duty. Available only with delay codes 10 & 20.
- 9 Available with Circuit Codes B & D only. VDE Certified to 30 amps. UL Recognized, CSA Accepted & TUV Certified to 50 amps.
- 10 Series Trip current ratings: VDE Certification available with single pole breakers with DC Delay only. UL Recognition & CSA Accepted available in one and two pole breakers.
- 11 Screw Terminals are recommended on ratings greater than 20 amps. Ratings over 30 amps are only available with Terminal Codes 5, 9, G, H, M and Q.
- 12 Terminal Code I: VDE Certification up to 25 amps and UL Recognition and CSA Accepted up to 30 amps, but not recommended over 20 amps.
- 13 Terminal Codes 3, 5 E & H (Bus Type) with VDE, are supplied with Lock Washers; Terminal Code M (M6 Threaded Stud) with VDE is supplied with Lock and Flat Washers. These breakers are only VDE Certified when the washers are used.
- 14 VDE Cert. available up to 12 amps. UL Rec. & CSA Accepted available up to 30 amps.
- 15 Single pole breakers with Terminal Code P (Printed Circuit Board) are available up to 30 amps with VDE Certification and 50 amps with UL Recognition and CSA Accepted, with Circuit Codes A, B & C. Two pole breakers with Terminal Code P (Printed Circuit Board) are available up to 40 amps with UL Recognition and CSA Certification with Circuit Codes A, B and C.
- 16 Terminal Code Q not available with VDE.
- 17 Terminal Code S used on voltage coil circuit constructions only.
- 18 Color shown is visi and legend with remainder of rocker black.
- 19 Dual = ON-OFF/I-O legend with actuator. None = no legend on actuator
- 20 Legend on Push-to-reset bezel/shroud is white with single color actuator codes R, & U. Legend on Push-to-reset bezel/shroud matches Visi-color of rocker with actuator codes N & O. Rockerguard available with actuator codes C through L.

Ordering Scheme Rocker - UL 489A Listed

Sample Part Number

A F 1 - B 0 - 14-450 - 1 3 1 - M T

Selection 1 2 3 4 5 6 7 8 9 10 11 12

1. SERIES

A

2. ACTUATOR ¹

Two Color Visi-Rocker
C Indicate ON, vertical legend
D Indicate ON, horizontal legend
F Indicate OFF, vertical legend
G Indicate OFF, horizontal legend
Single color
J Vertical legend
K Horizontal legend

Push-To-Reset, Visi-Rocker
N Indicate OFF, vertical legend
O Indicate OFF, horizontal legend
Push-To-Reset, Single color
R Vertical legend
U Horizontal legend

ROCKER STYLE DESCRIPTIONS			
	INDICATE "ON"	INDICATE "OFF"	SINGLE COLOR
VERTICAL STYLE	LINE INDICATE COLOR LOCATION 	CODE "C", "N" 	CODE "J", "R"
	HORIZONTAL STYLE 	CODE "D", "O" 	CODE "K", "U"

3. POLES ²

1 One 2 Two 3 Three

4. CIRCUIT

B Series Trip (Current)

5. AUXILIARY / ALARM SWITCH ²

0 without Aux Switch
 1 S.P.D.T., 0.093 Q.C. Term.
 2 S.P.D.T., 0.110 Q.C. Term.
 5 S.P.S.T., 0.093 Q.C. Term. (Gold Contacts)
 7 S.P.S.T., 0.110 Q.C. Term. (Gold Contacts)
 8 S.P.S.T., 0.187 Q.C. Term.
 9 S.P.D.T., 0.187 Q.C. Term.

6. FREQUENCY & DELAY

11 DC Ultra Short
 12 DC Short
 14 DC Medium
 16 DC Long
 52 DC, Short, High-inrush
 54 DC, Medium, High-inrush
 56 DC, Long, High-inrush

7. CURRENT RATING (AMPERES)

CODE	AMPERES						
210	0.100	285	0.850	455	5.500	613	13.000
215	0.150	290	0.900	460	6.000	614	14.000
220	0.200	295	0.950	465	6.500	615	15.000
225	0.250	410	1.000	470	7.000	616	16.000
230	0.300	512	1.250	475	7.500	617	17.000
235	0.350	415	1.500	480	8.000	618	18.000
240	0.400	517	1.750	485	8.500	620	20.000
245	0.450	420	2.000	490	9.000	622	22.000
250	0.500	522	2.250	495	9.500	624	24.000
255	0.550	527	2.750	610	10.000	625	25.000
260	0.600	430	3.000	710	10.500	630	30.000
265	0.650	435	3.500	611	11.000	635 ⁴	35.000
270	0.700	440	4.000	711	11.500	640 ⁴	40.000
275	0.750	445	4.500	612	12.000	645 ⁴	45.000
280	0.800	450	5.000	712	12.500	650 ⁴	50.000

8. TERMINAL ⁵

1⁶ Push-On 0.250 Tab (Q.C.)
 2 Screw 8-32 with upturned lugs
 3⁷ Screw 8-32 (Bus Type)
 4 Screw 10-32 with upturned lugs
 5⁷ Screw 10-32 (Bus Type)
 6 Screw 8-32 with upturned lugs & 30° bend
 7 Screw 8-32 (Bus Type) & 30° bend
 8 Screw 10-32 with upturned lugs & 30° bend
 9 Screw 10-32 (Bus Type) & 30° bend
 B Screw M5 with upturned lugs
 F Screw M5 with upturned lugs
 G Screw M5 (Bus Type) & 30° bend
 H Screw M5 (Bus Type)
 M⁷ M6 Threaded Stud
 P⁸ Printed Circuit Board Terminals
 Q⁹ Push-In Stud

9. ACTUATOR COLOR & LEGEND

Actuator or Visi-Color ¹⁰	Marking:		Marking Color	
	ON-OFF	Dual ¹⁰	Single Color	Visi-Rocker
White	B	1	Black	White
Black	D	2	White	n/a
Red	G	3	White	Red
Green	J	4	White	Green
Blue	L	5	White	Blue
Yellow	N	6	Black	Yellow
Gray	Q	7	Black	Gray
Orange	S	8	Black	Orange

10. MOUNTING / BARRIERS ²⁰

	STANDARD ROCKER BEZEL Threaded Insert, 2 per pole	BARRIERS
1	6-32 x 0.195 inches	no
A	6-32 X 0.195 inches (multi-pole units only)	yes
2	ISO M3 x 5mm	no
B	ISO M3 x 5mm (multi-pole units only)	yes
3	6-32 x 0.195 inches	no
C	6-32 x 0.195 inches (multi-pole units only)	yes
4	ISO M3 x 5mm	no
D	ISO M3 x 5mm (multi-pole units only)	yes
ROCKERGUARD & PUSH-TO-RESET BEZEL Threaded Insert, 2 per pole		
3	6-32 x 0.195 inches	no
C	6-32 x 0.195 inches (multi-pole units only)	yes
4	ISO M3 x 5mm	no
D	ISO M3 x 5mm (multi-pole units only)	yes
FRONT PANEL SNAP-IN BRACKET, 0.744" [18.90mm] wide bezel		
8	without Rockerguard (single pole units only)	no
H	with Rockerguard (single pole units only)	no
FRONT PANEL SNAP-IN BRACKET, 0.96" [24.48mm] wide bezel		
9	without Rockerguard (single pole units only)	no
J	with Rockerguard (single pole units only)	no

11. MAXIMUM APPLICATION RATING

M 80 DC

12. AGENCY APPROVAL

T UL489A Listed
 K UL489A Listed, VDE Certified
 J UL489A Listed, TUV Certified

Notes:

- 1 Push-To-Reset actuators have OFF portion of rocker shrouded.
- 2 Multi-pole breakers have all breakers identical except when specifying Auxiliary switch and/or mixed poles, and have one rocker per breaker.
- 3 Auxiliary Switch breakers with Series Trip circuits: < 30A, are supplied with standard half shells. 30-50A are supplied with extended boat (B-Style) half shells.
- 4 VDE Certification available with single pole breakers only. UL489A Listing available with one and two pole breakers.
- 5 Screw Terminals are recommended on ratings greater than 20 amps. Ratings over 30 amps are only available with Terminal Codes 5, 9, G, H, M and Q.
- 6 Terminal Code 1 (Push-On) available up to 25 amps with TUV or VDE Certification and 30 amps with UL489A Listing, but is not recommended over 20 amps.
- 7 Terminal Codes 3, 5 and H (Bus Type) with TUV or VDE, are supplied with Lock Washers, and Terminal Code M (M6 Threaded Stud) with VDE is supplied with Lock and Flat Washers. These breakers are only TUV or VDE Certified when the washers are used.
- 8 Single pole breakers with Terminal Code P (Printed Circuit Board) are available up to 30 amps with VDE Certification and 50 amps with UL489A Listing.
- 9 Terminal Code Q not available with VDE certification.
- 10 Color shown is Visi and Legend with remainder of rocker black. Dual = ON-OFF/-O legend.
- 11 Legend on Push-to-reset bezel/shroud is white with single color actuator codes R & U. Legend on Push-To-Reset bezel/shroud matches Visi-Color of rocker with actuator codes N & O. Rockerguard available with actuator codes C through K

[Configure Complete Part Number >](#)

[Browse Standard Parts >](#)

Circuit & Terminal Diagrams

Rocker

inches [millimeters]

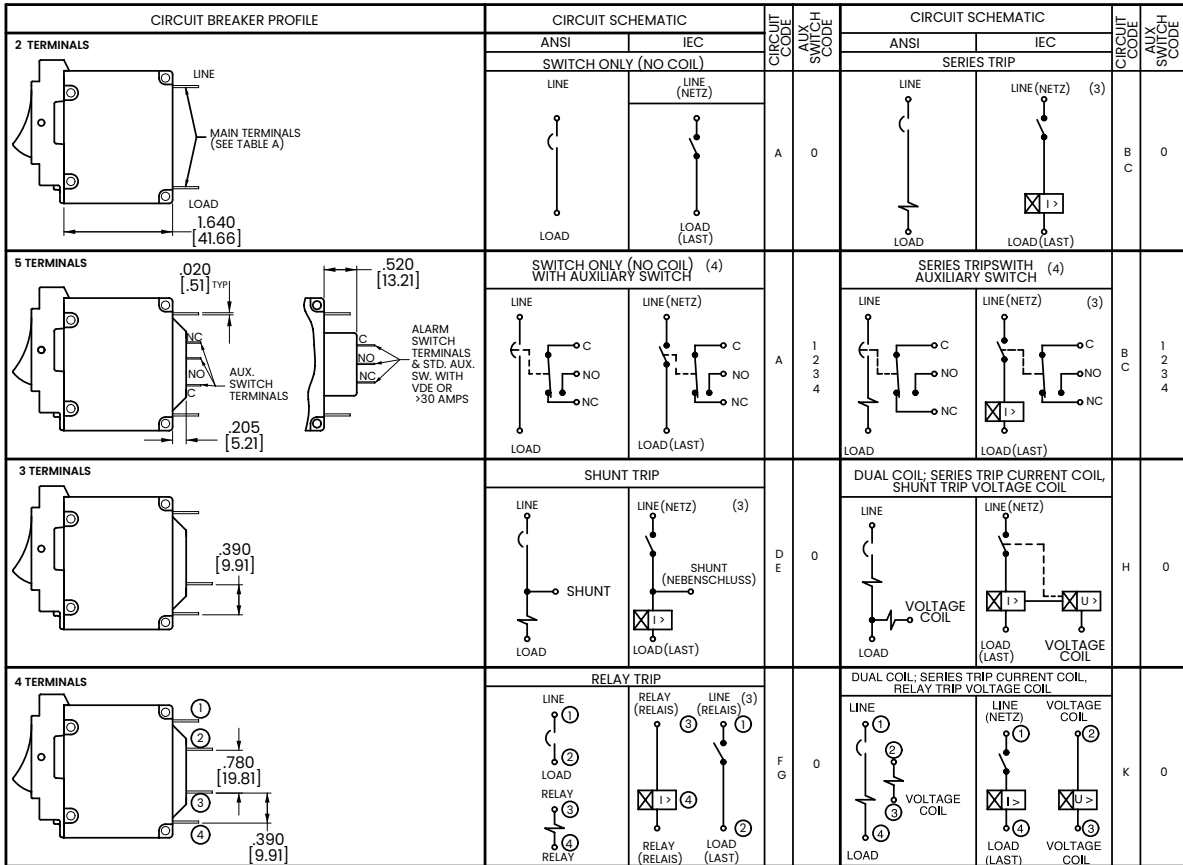

TERMINAL DESCRIPTION		DEPTH BEHIND PANEL
MAIN	TAB (Q.C.)	2.370 [60.20]
	SCREW TYPE	2.402 [61.01]
SHUNT, RELAY & DUAL COIL	TAB (Q.C.)	2.577 [65.46]
	SCREW #8-32 W/UPTURNED LUGS	2.734 [69.44]
AUX. SWITCH*	.093 TAB (Q.C.)	2.465 [62.61]
	.110 TAB (Q.C.) SOLDER TYPE	2.559 [65.00] 2.340 [59.44]

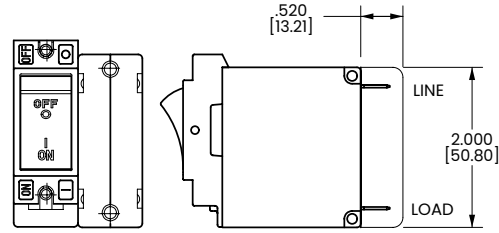

*AVAILABLE ON SERIES TRIP AND SWITCH ONLY CIRCUITS. WHEN CALLED FOR ON MULTI-POLE UNITS, ONLY ONE AUX. SWITCH IS NORMALLY SUPPLIED, AS SHOWN IN MULTI-POLE IDENTIFICATION SCHEME.

BARRIER FOR UL-RECOGNIZED MULTI-POLE BREAKERS

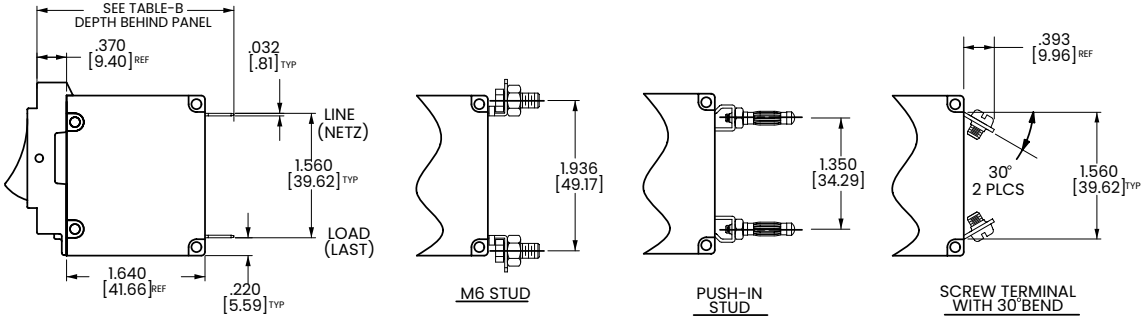

- Notes:
- 1 Tolerance $\pm .020$ [.51] unless otherwise specified.
 - 2 Schematic shown represents current trip circuit.
 - 3 Circuits shown for >30 amps / VDE.

Dimensional Specs

Rocker

inches [millimeters]

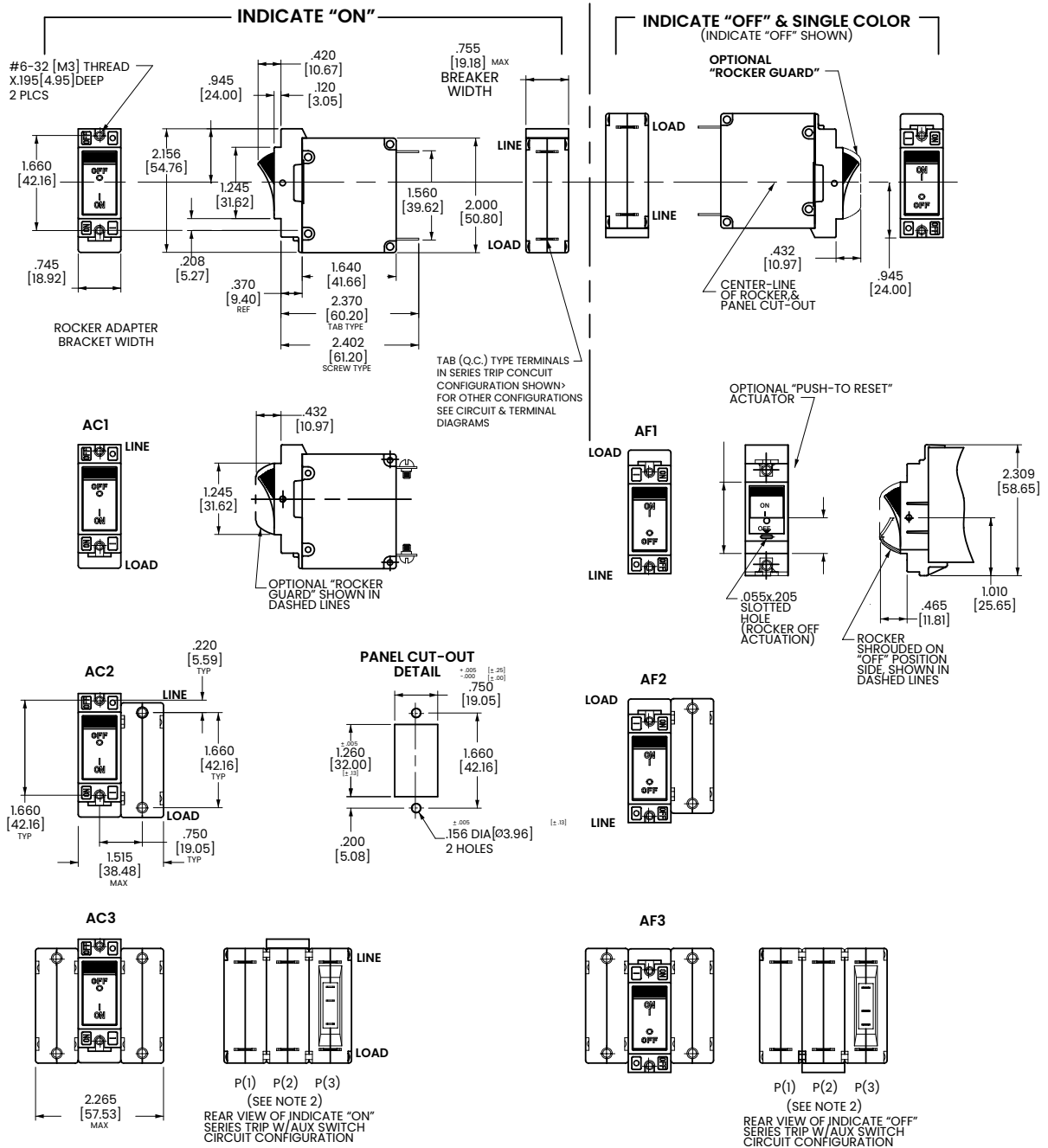

Notes:

- 1 Dimensions apply to all variations shown. Notice that circuit breaker line & load terminal orientation on indicate OFF is opposite of indicate ON.
- 2 For pole orientation with horizontal legend, rotate front view clockwise 90°.
- 3 Tolerance ± 0.20 [5.1] unless otherwise specified.

Dimensional Specs

Rocker Snap-In Bracket

inches [millimeters]

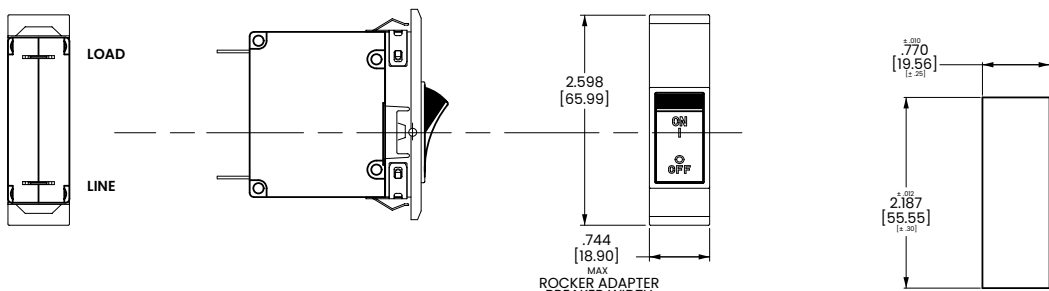
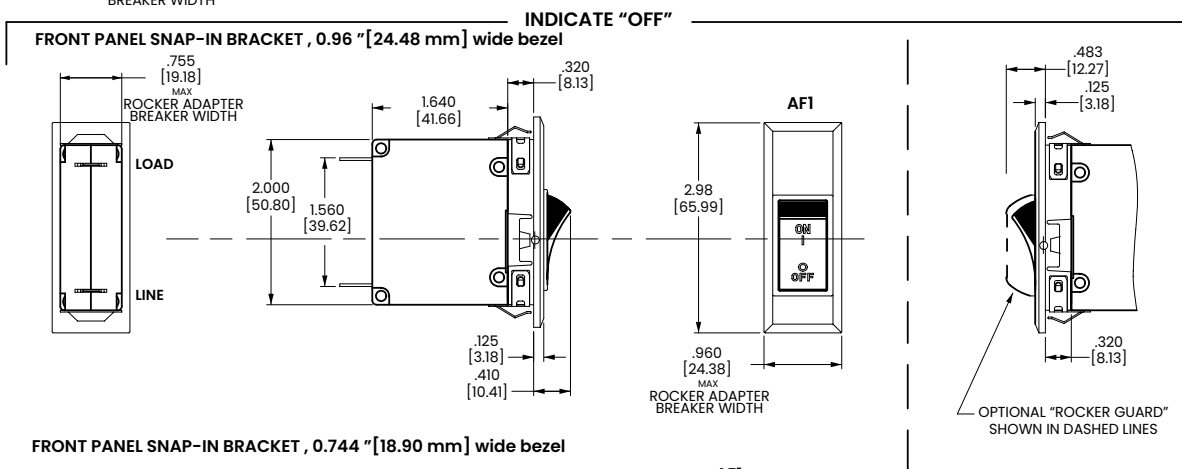
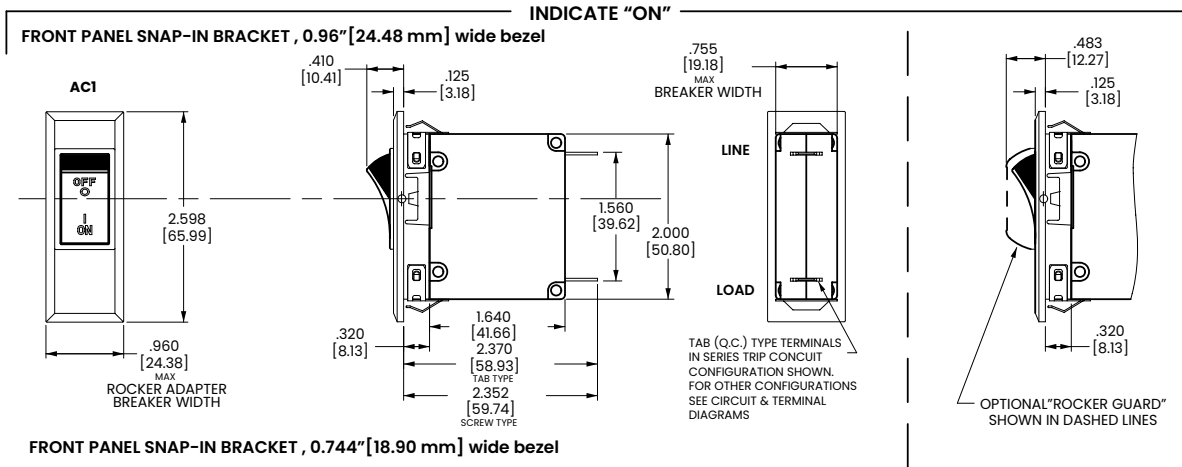

- Notes:
- 1 Dimensions apply to all variations shown. Notice that circuit breaker line & load terminal
 - 2 For pole orientation with horizontal legend, rotate front view clockwise 90°. Orientation on indicate "OFF" is opposite of indicate "ON"
 - 3 Recommended panel thickness: .040 [1.02] to .100 [2.54]
 - 4 Tolerance ±.020 [.51] unless otherwise specified.

PC Terminal Diagrams

inches [millimeters]

A-SERIES ROCKER

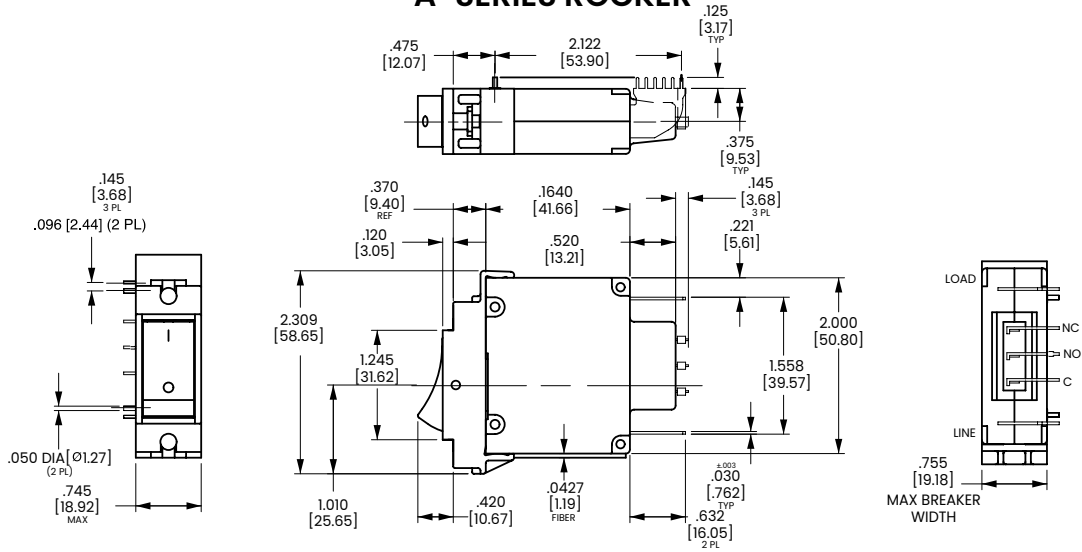

A-SERIES HANDLE

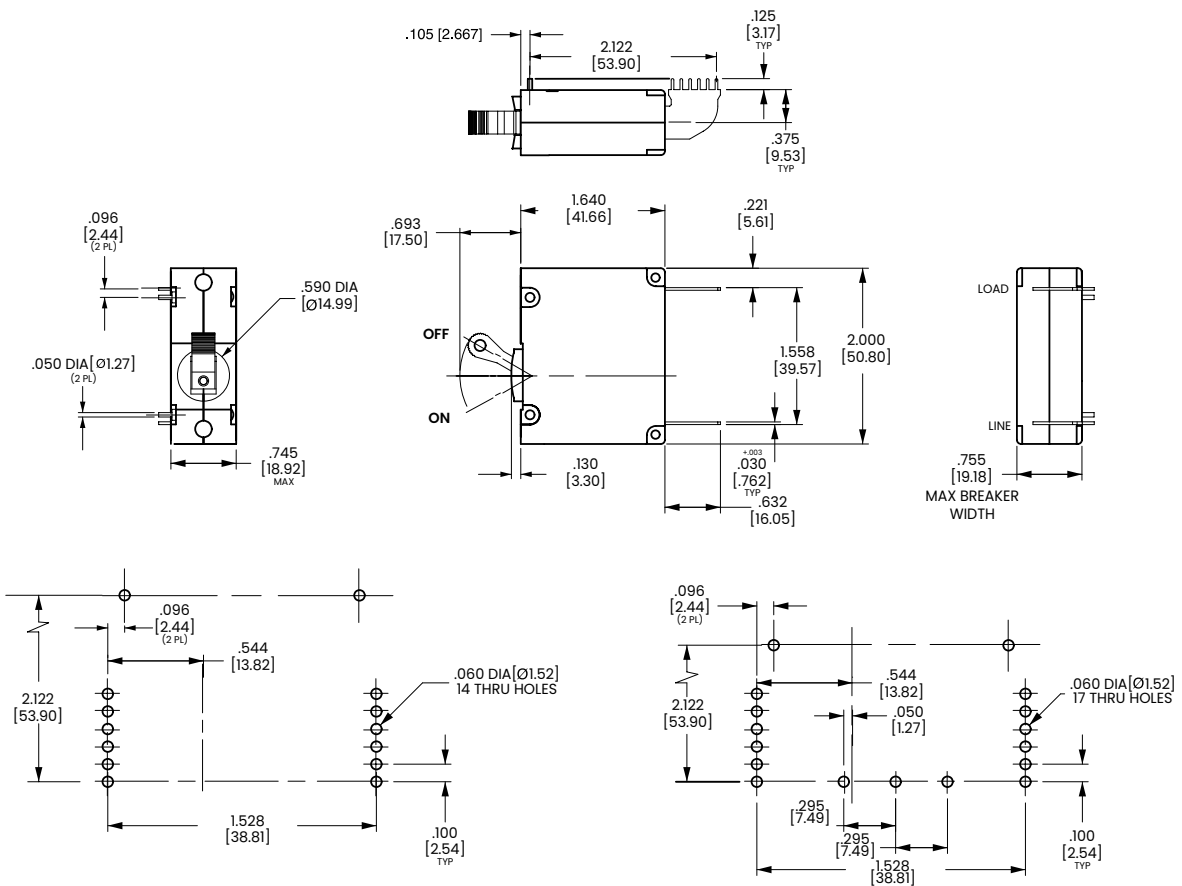

P.C. FOOT PRINT

P.C. FOOT PRINT WITH AUX. SWITCH

Notes:

- 1 Drawing illustrates A-Series with VDE certification.
- 2 Tolerance ± 0.20 [.51] unless otherwise specified

Ordering Scheme

Flat Rocker - UL 1077 Recognized

Sample Part Number

A 1 1 - B 0 - 24-630 - 2 3 1 - E

Selection

1 2 3 4 5 6 7 8 9 10 11

1. SERIES

A

2. ACTUATOR ¹

- Two Color Visi-Rocker**
1 Indicate OFF, vertical legend
2 Indicate OFF, horizontal legend
Single color
3 Vertical legend
4 Horizontal legend
Push-To-Reset, Visi-Rocker
5 Indicate OFF, vertical legend
6 Indicate OFF, horizontal legend
Push-To-Reset, Single color
7 Vertical legend
8 Horizontal legend

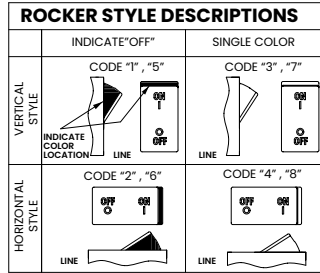

3. POLES ²

- 1** One **2** Two **3** Three

4. CIRCUIT

- A**³ Switch Only (No Coil) **G**⁴ Relay Trip (Voltage)
B Series Trip (Current) **H**^{4,5} Dual Coil with Shunt Trip
C Series Trip (Voltage) **K**^{4,5} Dual Coil with Relay Trip
D⁴ Shunt Trip (Current) Voltage Coil
E⁴ Shunt Trip (Voltage)
F⁴ Relay Trip (Current)

5. AUXILIARY / ALARM SWITCH ^{6,7}

- 0** without Aux Switch **7** S.P.S.T., 0.110 Q.C. Term. (Gold Contacts)
1 S.P.D.T., 0.093 Q.C. Term. **8** S.P.S.T., 0.187 Q.C. Term.
2 S.P.D.T., 0.110 Q.C. Term. **9** S.P.D.T., 0.187 Q.C. Term. (Gold Contacts)
5 S.P.S.T., 0.093 Q.C. Term. (Gold Contacts)

6. FREQUENCY & DELAY

- 03** DC 50/60Hz, Switch Only **31** DC, 50/60Hz Ultra Short
10⁶ DC Instantaneous **32** DC, 50/60Hz Short
11 DC Ultra Short **34** DC, 50/60Hz Medium
12 DC Short **36** DC, 50/60Hz Long
14 DC Medium **42**⁹ 50/60Hz Short, High-inrush
16 DC Long **44**⁹ 50/60Hz Medium, High-inrush
20⁶ 50/60Hz Instantaneous **46**⁹ 50/60Hz Long, High-inrush
21 50/60Hz Ultra Short **52**⁹ DC, Short, High-inrush
22 50/60Hz Short **54**⁹ DC, Medium, High-inrush
24 50/60Hz Medium **56** DC, Long, High-inrush
26 50/60Hz Long
30 DC, 50/60Hz Instantaneous

7. CURRENT RATING (AMPERES)

CODE	AMPERES						
020	0.020	225	0.250	420	2.000	611	11.000
025	0.025	230	0.300	522	2.250	711	11.500
030	0.030	235	0.350	527	2.750	612	12.000
035	0.035	240	0.400	430	3.000	712	12.500
040	0.040	245	0.450	435	3.500	613	13.000
045	0.045	250	0.500	440	4.000	614	14.000
050	0.050	255	0.550	445	4.500	615	15.000
055	0.055	260	0.600	450	5.000	616	16.000
060	0.060	265	0.650	455	5.500	617	17.000
065	0.065	270	0.700	460	6.000	618	18.000
070	0.070	275	0.750	465	6.500	620	20.000
075	0.075	280	0.800	470	7.000	622	22.000
080	0.080	285	0.850	475	7.500	624	24.000
085	0.085	290	0.900	480	8.000	625	25.000
090	0.090	295	0.950	485	8.500	630	30.000
095	0.095	410	1.000	490	9.000	635	35.000
210	0.100	512	1.250	495	9.500	640	40.000
215	0.150	415	1.500	610	10.000	645	45.000
220	0.200	517	1.750	710	10.500	650	50.000

OR VOLTAGE COIL (NORMAL RATED VOLTAGE) ⁸

A06	6 DC	A32	32 DC	J12	12 AC	J65	65 AC
A12	12 DC	A48	48 DC	J18	18 AC	K20	120 AC
A18	18 DC	A65	65 DC	J24	24 AC	L40	240 AC
A24	24 DC	J06	6 AC	J48	48 AC		

8. TERMINAL ¹¹

- 1**¹² Push-On 0.250 Tab (Q.C.) **C** Screw, M4 with upturned lugs
2 Screw 8-32 with upturned lugs **E**¹³ Screw M4 (Bus Type)
3¹³ Screw 8-32 (Bus Type) **F** Screw M5 with upturned lugs & 30° bend
4 Screw 10-32 with upturned lugs **G** Screw M5 (Bus Type) & 30° bend
5¹³ Screw 10-32 (Bus Type) **H**¹³ Screw M5 (Bus Type)
6 Screw 8-32 with upturned lugs & 30° bend **L**¹⁴ 0.250 Q.C./ Solder Lug
7 Screw 8-32 (Bus Type) **M**¹³ M6 Threaded Stud
8 Screw 10-32 with upturned lugs & 30° bend **P**¹⁵ Printed Circuit Board Terminals
9 Screw 10-32 (Bus Type) **Q** Push-In Stud
B Screw M5 with upturned lugs **R** Screw, M4 with upturned lugs & 30° Bend
S¹⁶ Push-On 0.110 Tab (Q.C.)
T Screw, M4 with upturned lugs

9. ACTUATOR COLOR & LEGEND

Actuator or Visi-Color ¹⁷	Marking:		Marking Color	
	ON-OFF	Dual ¹⁷	Single Color	Visi-Rocker
White	B	1	Black	White
Black	D	2	White	n/a
Red	G	3	White	Red
Green	J	4	White	Green
Blue	L	5	White	Blue
Yellow	N	6	Black	Yellow
Gray	Q	7	Black	Gray
Orange	S	8	Black	Orange

10. MOUNTING / BARRIERS ¹⁸

STANDARD ROCKER BEZEL Threaded Insert, 2 per pole BARRIERS

FLAT ROCKER ACTUATOR	
1 6-32 x 0.195 inches	no
A 6-32 x 0.195 inches (multi-pole units only)	yes
2 ISO M3 x 5mm	no
B ISO M3 x 5mm (multi-pole units only)	yes

RECESSED OFF SIDE ROCKER ACTUATOR ¹⁹

5 6-32 x 0.195 inches	no
E 6-32 x 0.195 inches (multi-pole units only)	yes
6 ISO M3 x 5mm	no
F ISO M3 x 5mm (multi-pole units only)	yes

PUSH-TO-RESET BEZEL, Threaded Insert, 2 per pole

3 6-32 x 0.195 inches	no
C 6-32 x 0.195 inches (multi-pole units only)	yes
4 ISO M3 x 5mm	no
D ISO M3 x 5mm (multi-pole units only)	yes

11. AGENCY APPROVAL

- C** UL Recognized & CSA Accepted
E TUV Certified, UL Recognized & CSA Accepted
I UL Recognized STD 1077, UL Recognized 1500 (ignition protected), & CSA Accepted

Notes:

- Push-To-Reset actuators have OFF portion of rocker shrouded.
- Multi-pole breakers have all breakers identical except when specifying Auxiliary switch and/or mixed poles, and have one rocker per breaker.
- Switch Only circuits, rated up to 50 amps & 3 poles. Only available when tied to a protected pole. For .02 to 30 amps, select Current Code 630. For 35 - 50 amps, select Current Code 650.
- Available with terminal Codes 1, 2 and 3. Current Rating limited to 30 amps maximum.
- Consult factory for Dual Coil options, as special catalog number is required. With Shunt construction, Dual Coils will trip instantaneously on line voltage. Dual coils require 30VA minimum power to trip and are rated for intermittent duty only.
- Auxiliary Switch breakers with Series Trip & Switch Only circuits: ≤ 30A, are supplied with standard half shells. 30-50A are supplied with extended boat (B-Style) half shells.
- On multi-pole breakers, one auxiliary switch is supplied, mounted in the extreme right pole.
- Separate pole type voltage coils not rated for continuous duty. Available only with delay codes 10 & 20.
- Available with Circuit Codes B & D only. UL Recognized, CSA Accepted & TUV Certified to 50 amps.
- UL Recognition, CSA Acceptance & TUV Certification available in one and two pole breakers.
- Screw Terminals are recommended on ratings greater than 20 amps. Ratings over 30 amps are only available with Terminal Codes 5, 9, G, H, M and Q.
- Terminal Code I: Available up to 30 amps, but not recommended over 20 amps.
- Terminal Codes 3, 5 E & H (Bus Type) with TUV, are supplied with Lock Washers; Terminal Code M (M6 Threaded Stud) with TUV is supplied with Lock and Flat Washers. These breakers are only TUV Certified when the washers are used.
- TUV Cert. available up to 12 amps. UL Rec. & CSA Accepted available up to 30 amps.
- Single pole breakers with Terminal Code P (Printed Circuit Board) are available up to 50 amps with UL Recognition, CSA Accepted & TUV Certification, with Circuit Codes A, B and C. Two pole breakers with Terminal Code P (Printed Circuit Board) are available up to 40 amps with UL Recognition and CSA Accepted with Circuit Codes A, B & C.
- Terminal Code S used on voltage coil circuit constructions only.
- Color shown is visi & legend with remainder of rocker black, Dual = ON-OFF/I-O legend.
- Legend on Push-to-reset bezel/shroud is white with single color actuator codes 7 & 8. Legend on Push-To-Reset bezel/shroud matches Visi-Color of rocker with actuator codes 5 & 6.
- Recessed "off-side" available with actuator codes 1, 2, 3 & 4. Legends on rocker are available in ink stamping only.

Configure Complete Part Number >

Browse Standard Parts >

Ordering Scheme

Flat Rocker - UL 489A Listed

Sample Part Number

A 1 1 - B 0 - 14 - 630 - 2 3 1 - M T

Selection 1 2 3 4 5 6 7 8 9 10 11 12

1. SERIES

A

2. ACTUATOR ¹

- Two Color Visi-Rocker
- 1 Indicate OFF, vertical legend
- 2 Indicate OFF, horizontal legend
- Single color
- 3 Vertical legend
- 4 Horizontal legend
- Push-To-Reset, Visi-Rocker
- 5 Indicate OFF, vertical legend
- 6 Indicate OFF, horizontal legend
- Push-To-Reset, Single color
- 7 Vertical legend
- 8 Horizontal legend

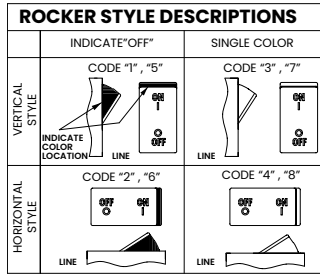

3. POLES ²

1 One 2 Two 3 Three

4. CIRCUIT

B Series Trip (Current)

5. AUXILIARY / ALARM SWITCH ³

0	without Aux Switch	7	S.P.S.T., 0.110 Q.C. Term. (Gold Contacts)
1	S.P.D.T., 0.093 Q.C. Term.	8	S.P.S.T., 0.187 Q.C. Term.
2	S.P.D.T., 0.110 Q.C. Term.	9	S.P.D.T., 0.187 Q.C. Term.

6. FREQUENCY & DELAY

11	DC Ultra Short	52	DC, Short, High-inrush
12	DC Short	54	DC, Medium, High-inrush
14	DC Medium	56	DC, Long, High-inrush
16	DC Long		

7. CURRENT RATING (AMPERES)

CODE	AMPERES						
020	0.020	225	0.250	420	2.000	611	11.000
025	0.025	230	0.300	522	2.250	711	11.500
030	0.030	235	0.350	527	2.750	612	12.000
035	0.035	240	0.400	430	3.000	712	12.500
040	0.040	245	0.450	435	3.500	613	13.000
045	0.045	250	0.500	440	4.000	614	14.000
050	0.050	255	0.550	445	4.500	615	15.000
055	0.055	260	0.600	450	5.000	616	16.000
060	0.060	265	0.650	455	5.500	617	17.000
065	0.065	270	0.700	460	6.000	618	18.000
070	0.070	275	0.750	465	6.500	620	20.000
075	0.075	280	0.800	470	7.000	622	22.000
080	0.080	285	0.850	475	7.500	624	24.000
085	0.085	290	0.900	480	8.000	625	25.000
090	0.090	295	0.950	485	8.500	630	30.000
095	0.095	410	1.000	490	9.000	635 ⁴	35.000
210	0.100	512	1.250	495	9.500	640 ⁴	40.000
215	0.150	415	1.500	610	10.000	645 ⁴	45.000
220	0.200	517	1.750	710	10.500	650 ⁴	50.000

8. TERMINAL ¹¹

2	Screw 8-32 with upturned lugs	9	Screw 10-32 (Bus Type) & 30° bend
3 7	Screw 8-32 (Bus Type)	B	Screw M5 with upturned lugs
4	Screw 10-32 with upturned lugs	F	Screw M5 with upturned lugs
5 7	Screw 10-32 (Bus Type)	G	Screw M5 (Bus Type) & 30° bend
6	Screw 8-32 with upturned lugs & 30° bend	H	Screw M5 (Bus Type)
8	Screw 10-32 with upturned lugs & 30° bend	M 7	M6 Threaded Stud
		P 8	Printed Circuit Board Terminals
		Q 9	Push-In Stud

9. ACTUATOR COLOR & LEGEND

Actuator or Visi-Color ¹¹	Marking:		Marking Color	
	ON-OFF	Dual ¹¹	Single Color	Visi-Rocker
White	B	1	Black	White
Black	D	2	White	n/a
Red	G	3	White	Red
Green	J	4	White	Green
Blue	L	5	White	Blue
Yellow	N	6	Black	Yellow
Gray	Q	7	Black	Gray
Orange	S	8	Black	Orange

10. MOUNTING / BARRIERS ¹²

	STANDARD ROCKER BEZEL Threaded Insert, 2 per pole FLAT ROCKER ACTUATOR	BARRIERS
1	6-32 x 0.195 inches	no
A	6-32 x 0.195 inches (multi-pole units only)	yes
2	ISO M3 x 5mm	no
B	ISO M3 x 5mm (multi-pole units only)	yes
	RECESSED OFF SIDE ROCKER ACTUATOR	
5	6-32 x 0.195 inches	no
E	6-32 x 0.195 inches (multi-pole units only)	yes
6	ISO M3 x 5mm	no
F	ISO M3 x 5mm (multi-pole units only)	yes
	PUSH-TO-RESET BEZEL, Threaded Insert, 2 per pole	
3	6-32 x 0.195 inches	no
C	6-32 x 0.195 inches (multi-pole units only)	yes
4	ISO M3 x 5mm	no
D	ISO M3 x 5mm (multi-pole units only)	yes

11. MAXIMUM APPLICATION RATING

M 80 DC

12. AGENCY APPROVAL

T UL489A Listed
J UL489A Listed, TUV Certified

Notes:

- 1 Push-To-Reset actuators have OFF portion of rocker shrouded.
- 2 Multi-pole breakers have all breakers identical except when specifying Auxiliary switch and/or mixed poles, and have one rocker per breaker.
- 3 Auxiliary Switch breakers with Series Trip circuits: ≤ 30A, are supplied with standard half shells. 30-50A are supplied with extended boat (B-Style) half shells.
- 4 VDE Certification available with single pole breakers only. UL489A Listing available with one and two pole breakers.
- 5 Screw Terminals are recommended on ratings greater than 20 amps. Ratings over 30 amps are only available with Terminal Codes 5, 9, G, H, M and Q.
- 6 Terminal Code 1 (Push-On) available up to 25 amps with TUV or VDE Certification and 30 amps with UL489A listing, but is not recommended over 20 amps.
- 7 Terminal Codes 3, 5 and H (Bus Type) with TUV or VDE, are supplied with Lock Washers, and Terminal Code M (M6 Threaded Stud) with VDE is supplied with Lock and Flat Washers. These breakers are only TUV or VDE Certified when the washers are used.
- 8 Single pole breakers with Terminal Code P (Printed Circuit Board) are available up to 30 amps with VDE Certification and 50 amps with UL489A Listing.
- 9 Terminal Code Q not available with VDE certification.
- 10 Color shown is Visi and Legend with remainder of rocker black. Dual = ON-OFF/I-O legend.
- 11 Legend on Push-to-reset bezel/shroud is white with single color actuator codes R & U.
- 12 Legend on Push-To-Reset bezel/shroud matches Visi-Color of rocker with actuator codes N & O. Rockerguard available with actuator codes C through K

[Configure Complete Part Number >](#)

[Browse Standard Parts >](#)

Dimensional Specs Flat Rocker

inches [millimeters]

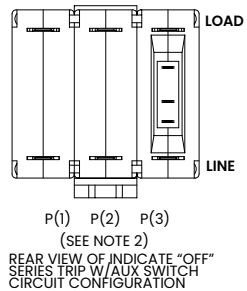
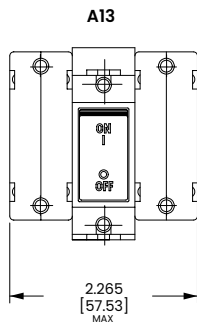
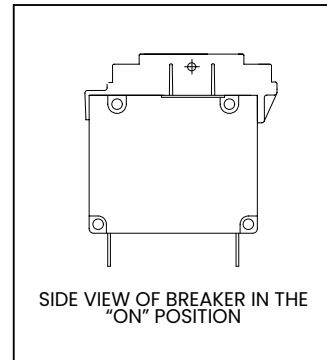
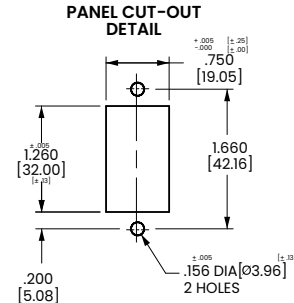
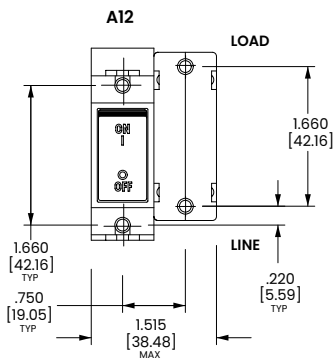
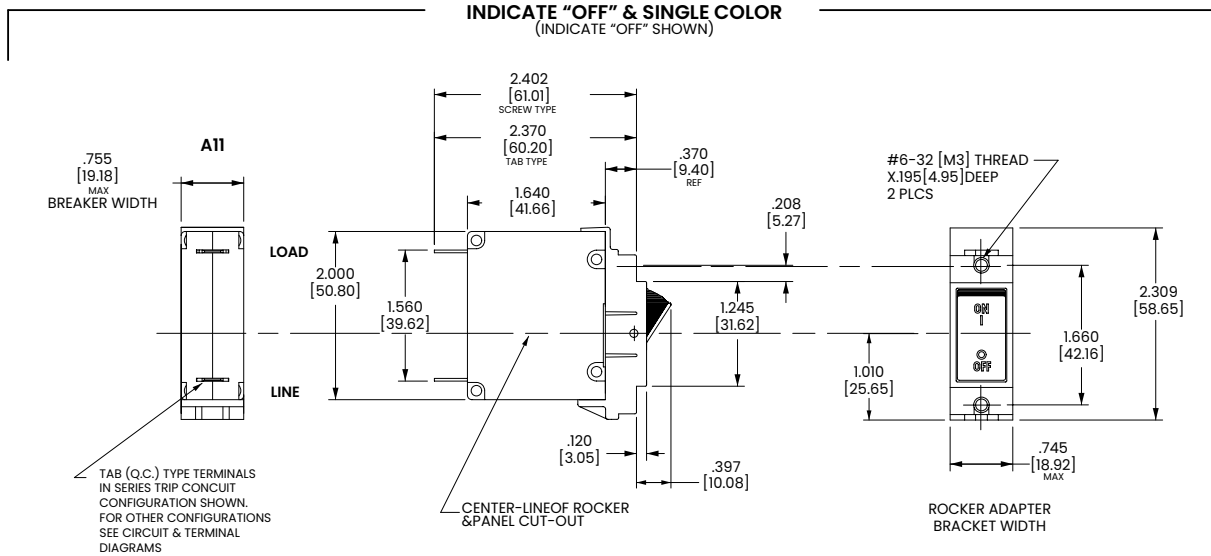

PUSH-TO-RESET ACTUATOR

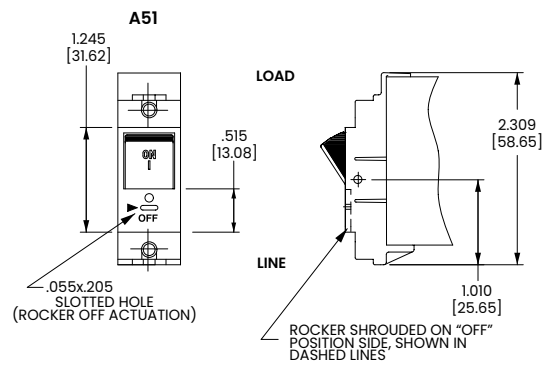

ACTUATOR SIDE VIEW (SURFACE CONTOURS)

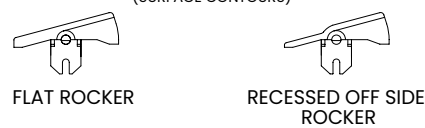

- Notes:
 1 For pole orientation with horizontal legend, rotate front view clockwise 90°.
 2 Tolerance ± 0.20 [5.1] unless otherwise specified.

Ordering Scheme Recessed Paddle

Sample Part Number

A Y 1 - B 0 - 14 - 630 - 2 3 1 - M T

Selection 1 2 3 4 5 6 7 8 9 10 11 12

1. SERIES

A

2. ACTUATOR ¹

Y Single Color Recessed Paddle Actuator with Vertical Legends

3. POLES ²

1 One **2** Two **3** Three

4. CIRCUIT

A Switch-Only (No Coil) **F** Relay Trip (Current)
B Series Trip (Current) **G** Relay Trip (Voltage)
C Series Trip (Voltage) **H** Dual Coil with Shunt Trip Voltage Coil
D Shunt Trip (Current) **K** Dual Coil with Shunt Trip Current Coil
E Shunt Trip (Voltage)

5. AUXILIARY SWITCH

0 without Aux Switch
1 S.P.D.T. with 0.093 Q.C. Terminals
2 S.P.D.T. with 0.110 Q.C. Terminals
3 S.P.D.T. with 0.139 Solder Lug Terminals
5 S.P.D.T. with 0.093 Q.C. Terminals (Gold Contacts)
6 S.P.S.T.-N.O. with 0.139 Solder Lug Terminals
7 S.P.S.T.-N.O. with 0.110 Q.C. Terminals (Gold Contacts)
8 S.P.S.T.-N.O. with 0.187 Q.C. Terminals
9 S.P.D.T. with 0.187 Q.C. Terminals

6. FREQUENCY & DELAY ³

3 DC, 50/60 Hz Switch Only	24 50/60 Hz Medium
10 DC Instantaneous	26 50/60 Hz Long
11 DC Ultra Short	42 50/60 Hz Short High-inrush
12 DC Short	44 50/60 Hz Medium High-inrush
14 DC Medium	46 50/60 Hz Long High-inrush
16 DC Long	52 DC, Short, High-inrush
20 50/60 Hz Instantaneous	54 DC, Medium, High-inrush
21 50/60 Hz Ultra Short	56 DC, Long, High-inrush
22 50/60 Hz Short	

7. CURRENT RATING (AMPERES) ⁴

CODE	AMPERES						
020	0.020	225	0.250	420	2.000	611	11.000
025	0.025	230	0.300	522	2.250	711	11.500
030	0.030	235	0.350	527	2.750	612	12.000
035	0.035	240	0.400	430	3.000	712	12.500
040	0.040	245	0.450	435	3.500	613	13.000
045	0.045	250	0.500	440	4.000	614	14.000
050	0.050	255	0.550	445	4.500	615	15.000
055	0.055	260	0.600	450	5.000	616	16.000
060	0.060	265	0.650	455	5.500	617	17.000
065	0.065	270	0.700	460	6.000	618	18.000
070	0.070	275	0.750	465	6.500	620	20.000
075	0.075	280	0.800	470	7.000	622	22.000
080	0.080	285	0.850	475	7.500	624	24.000
085	0.085	290	0.900	480	8.000	625	25.000
090	0.090	295	0.950	485	8.500	630	30.000
095	0.095	410	1.000	490	9.000	635	35.000
210	0.100	512	1.250	495	9.500	640	40.000
215	0.150	415	1.500	610	10.000	645	45.000
220	0.200	517	1.750	710	10.500	650	50.000

OR VOLTAGE COIL (NORMAL RATED VOLTAGE)

A06 6 DC	A32 32 DC	J12 12 AC	J65 65 AC
A12 12 DC	A48 48 DC	J18 18 AC	K20 120 AC
A18 18 DC	A65 65 DC	J24 24 AC	L40 240 AC
A24 24 DC	J06 6 AC	J48 48 AC	

8. TERMINAL

1 Push-On 0.250 Tab (Q.C.)	B Screw M5 with upturned lugs
2 Screw 8-32 with upturned lugs	C Screw, M4 with upturned lugs
3 7 Screw 8-32 (Bus Type)	F Screw M5 with upturned lugs
4 Screw 10-32 with upturned lugs	G Screw M5 (Bus Type) & 30° bend
5 7 Screw 10-32 (Bus Type)	H Screw M5 (Bus Type)
6 Screw 8-32 with upturned lugs & 30° bend	M M6 Threaded Stud
7 Screw 8-32 (Bus Type) & 30° bend	P Printed Circuit Board Terminals
8 Screw 10-32 with upturned lugs & 30° bend	Q Push-In Stud
9 Screw 10-32 (Bus Type) & 30° bend	R Screw, M4 with upturned lugs & 30° Bend
	S Screw, M5 with upturned lugs
	T Screw, M4 with upturned lugs

9. ACTUATOR COLOR & LEGEND ⁵

Actuator Color	I-O	ON-OFF	Dual	Legend Color
White	A	B	1	Black
Black	C	D	2	White
Red	F	G	3	White
Green	H	J	4	White
Blue	K	L	5	White
Yellow	M	N	6	Black
Gray	P	Q	7	Black
Orange	R	S	8	Black

10. MOUNTING / BARRIERS

		BARRIERS
1	6-32 x 0.195 inches	no
A	6-32 x 0.195 inches (multi-pole units only)	yes
2	ISO M3 x 5mm	no
B	ISO M3 x 5mm (multi-pole units only)	yes

11. MAXIMUM APPLICATION RATING ⁶

A 65 VDC
C 120/240 VAC (Available only on 2 or 3-Pole units)
K 120 VAC
M 80 DC

12. AGENCY APPROVAL ⁷

A Without Approvals
C UL Recognized and CSA Accepted
T UL 489A

Notes:

- All standard catalog numbers are supplied with Vertical Legends. For Horizontal or other non-standard legends, choose "X" and order as a special catalog number.
- For rating (T) 2 & 3 Pole not available.
- Frequency and Time Delay ratings of (03, 20, 21, 22, 24, 26, 42, 44, 46) not available with approval T.
- Voltage Coil Ratings starting with (J, K, or L) not available with approval T.
- "OFF" and/or "O" Legends are on Bracket and are only visible when the Paddle Actuator is in the off position.
- Maximum Application Ratings (C & K) not available with approval T.
- Not all approvals are available in all constructions. Consult factory for details.

[Configure Complete Part Number >](#)

[Browse Standard Parts >](#)

Dimensional Specs Recessed Paddle

inches [millimeters]

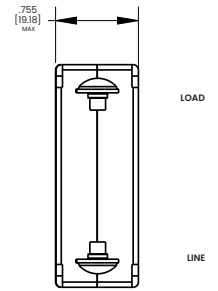
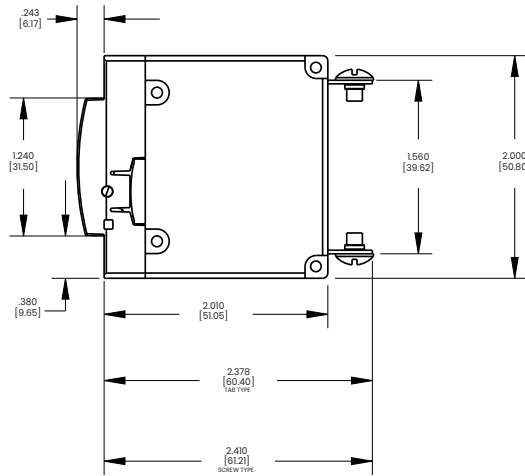
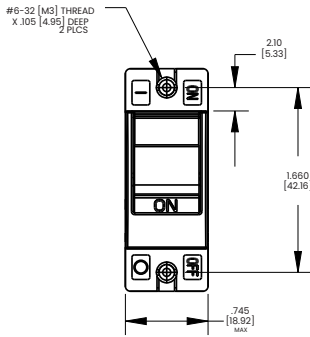

BREAKER SHOWN IN THE OFF POSITION

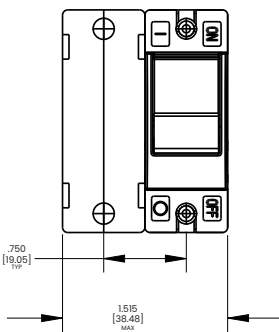

BREAKER SHOWN IN THE OFF POSITION

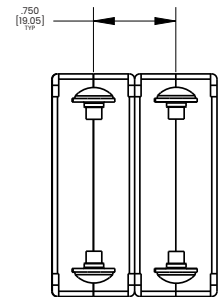
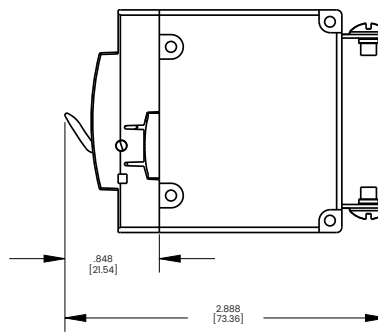

PANEL CUT-OUT DETAIL

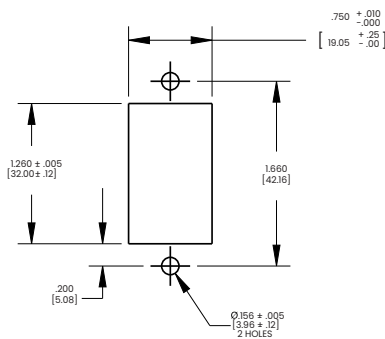
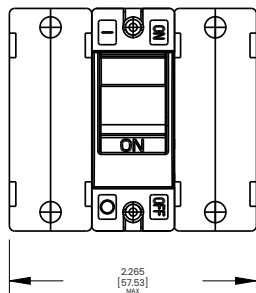

Notes:

- 1 Tolerance ± 0.20 [.51] unless otherwise specified

Authorized Sales Representatives and Distributors

Click on a region of the map below to find your local representatives and distributors or visit www.carlingtech.com/findarep.



About Carling

Founded in 1920, Carling Technologies is a leading manufacturer of electrical and electronic switches and assemblies, circuit breakers, electronic controls, power distribution units, and multiplexed power distribution systems. With six ISO9001 and IATF16949 registered manufacturing facilities and technical sales offices worldwide, Carling Technologies Sales, Service and Engineering teams do much more than manufacture electrical components, they engineer powerful solutions! To learn more about Carling please visit www.carlingtech.com/company-profile.

To view all of Carling's environmental, quality, health & safety certifications please visit www.carlingtech.com/environmental-certifications.